

Riduttori Vite Senza Fine - (MRDV/RDV)
 Worm-gear speed reducer (MRDV/RDV)

MRDV 025

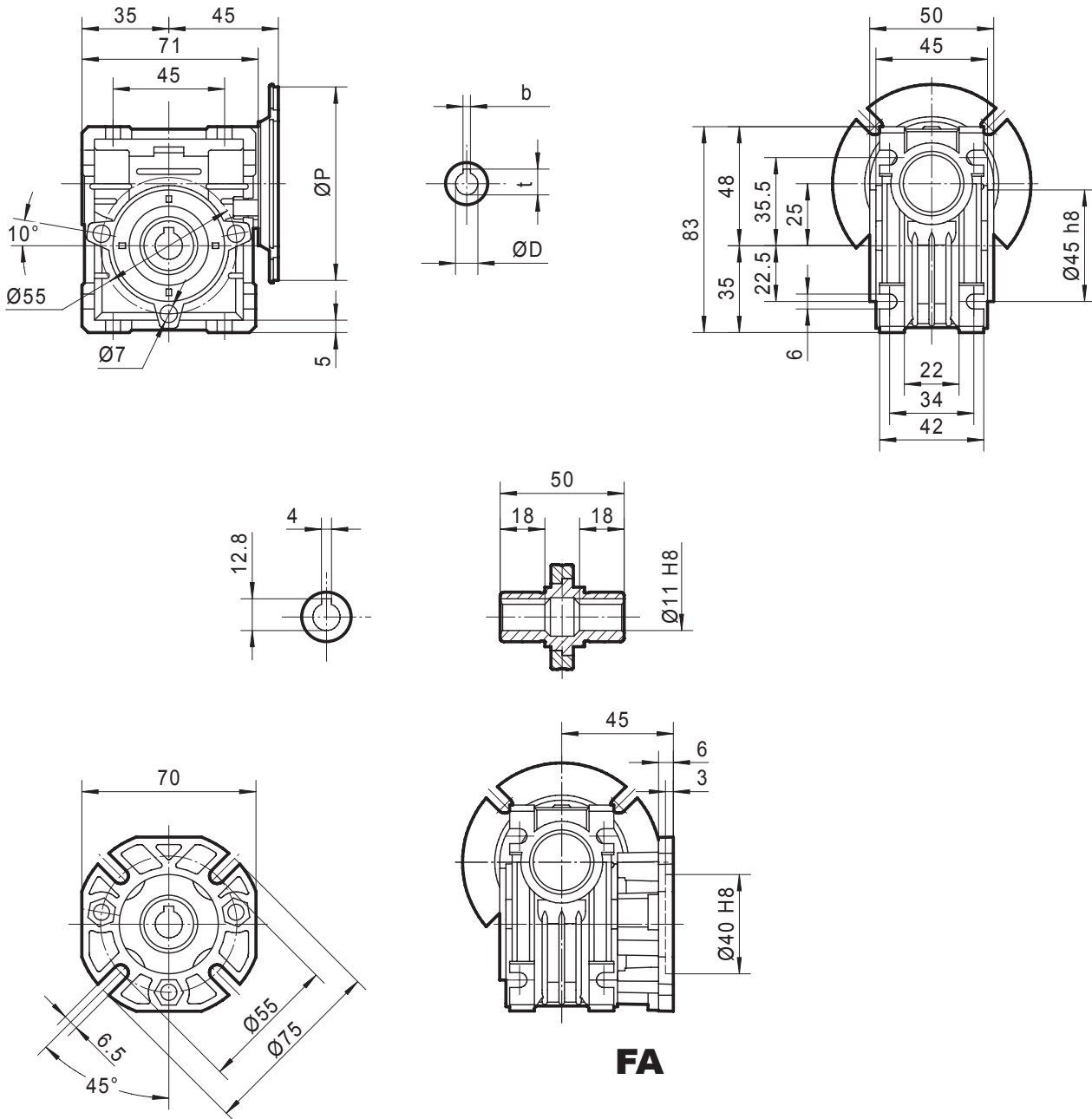

Peso senza motore \approx **0.7 kg**

Weight without motor \approx **0.7 kg**

Per le dimensioni dei motori, dati (P, D, b, t), consultare la tabella a pag. 78

For the dimensions concerning the motor connection area (P, D, b, t) please refer to the table shown at page 78.

DIMENSIONI MRDV - MRDV SERIES DIMENSIONS

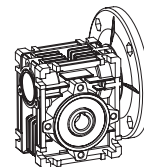

MRDV 030

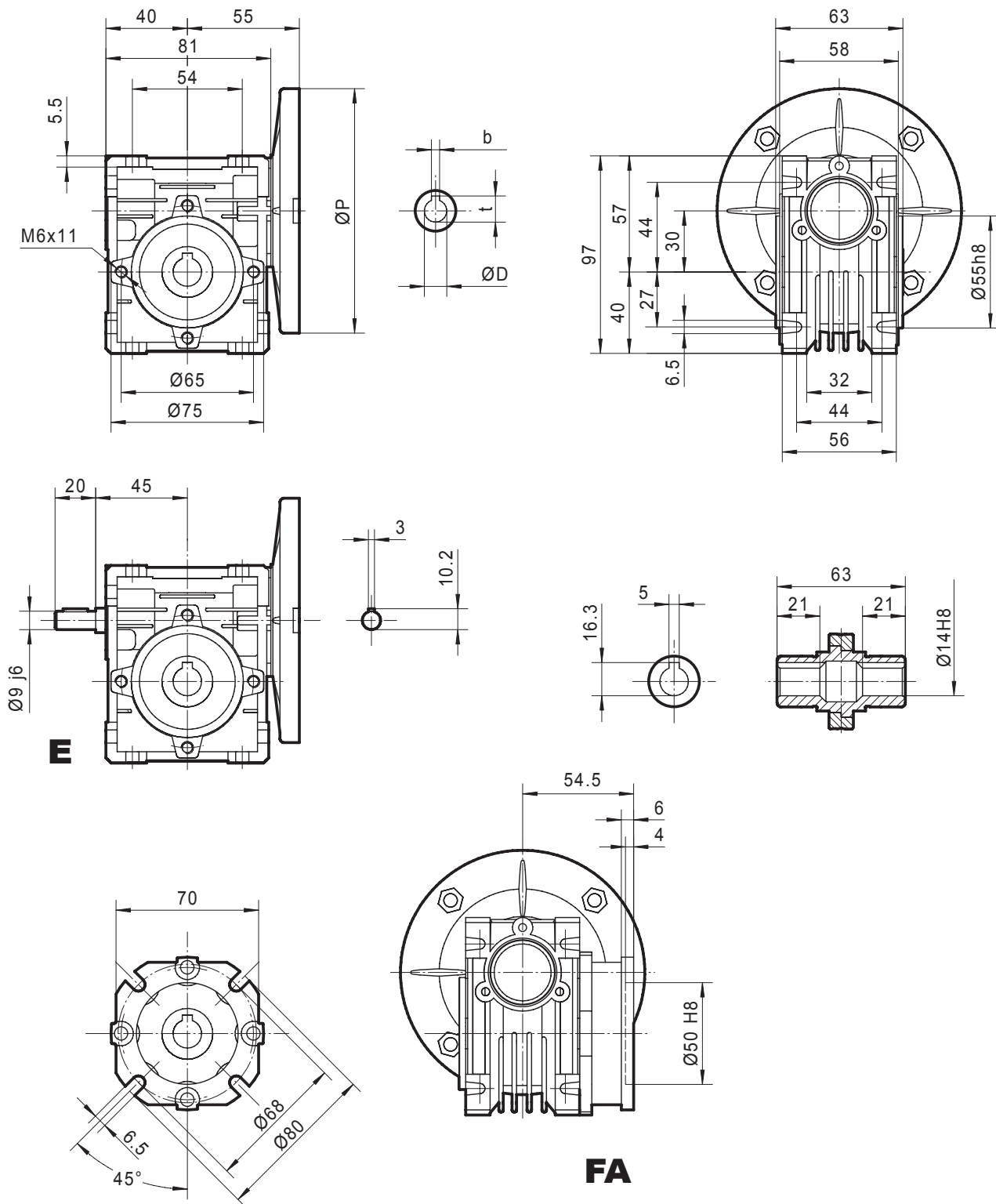

Peso senza motore ≈ 1.2 kg

Weight without motor ≈ 1.2 kg

Per le dimensioni dei motori, dati (P, D, b, t), riferirsi alla tabella a pag 78.

For the dimensions concerning the motor connection area (P, D, b, t) please refer to the table shown at page 78.

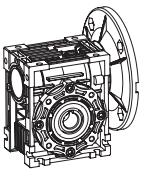

DIMENSIONI MRDV - MRDV SERIES DIMENSIONS

MRDV 040

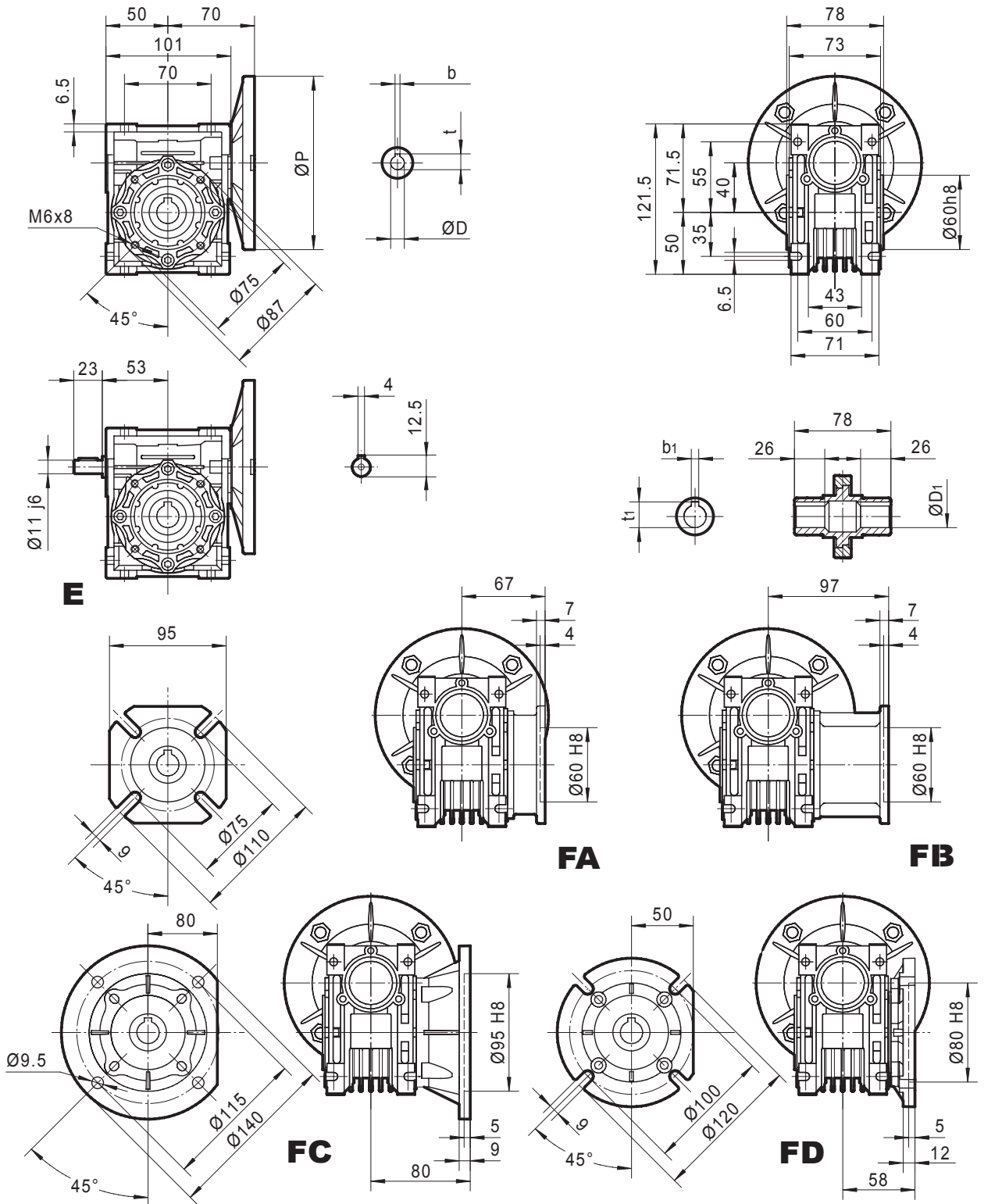

Peso senza motore ≈ 2.3 kg Weight without motor ≈ 2.3 kg

Per i dati dei motori (P, D, b, t), riferirsi alla tab. pag.78

For the dimensions concerning the motor connection area (P, D, b, t) please refer to the table shown at page 78.

Albero in uscita Output size		
ØD ₁ H8	b ₁	t ₁
Ø18	6	20.8
Ø19*	6*	21.8*

(*) modello non standard

(*) Nonstandard model

DIMENSIONI MRDV – MRDV SERIES DIMENSIONS

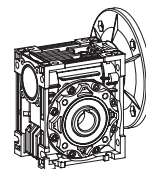

MRDV **050**

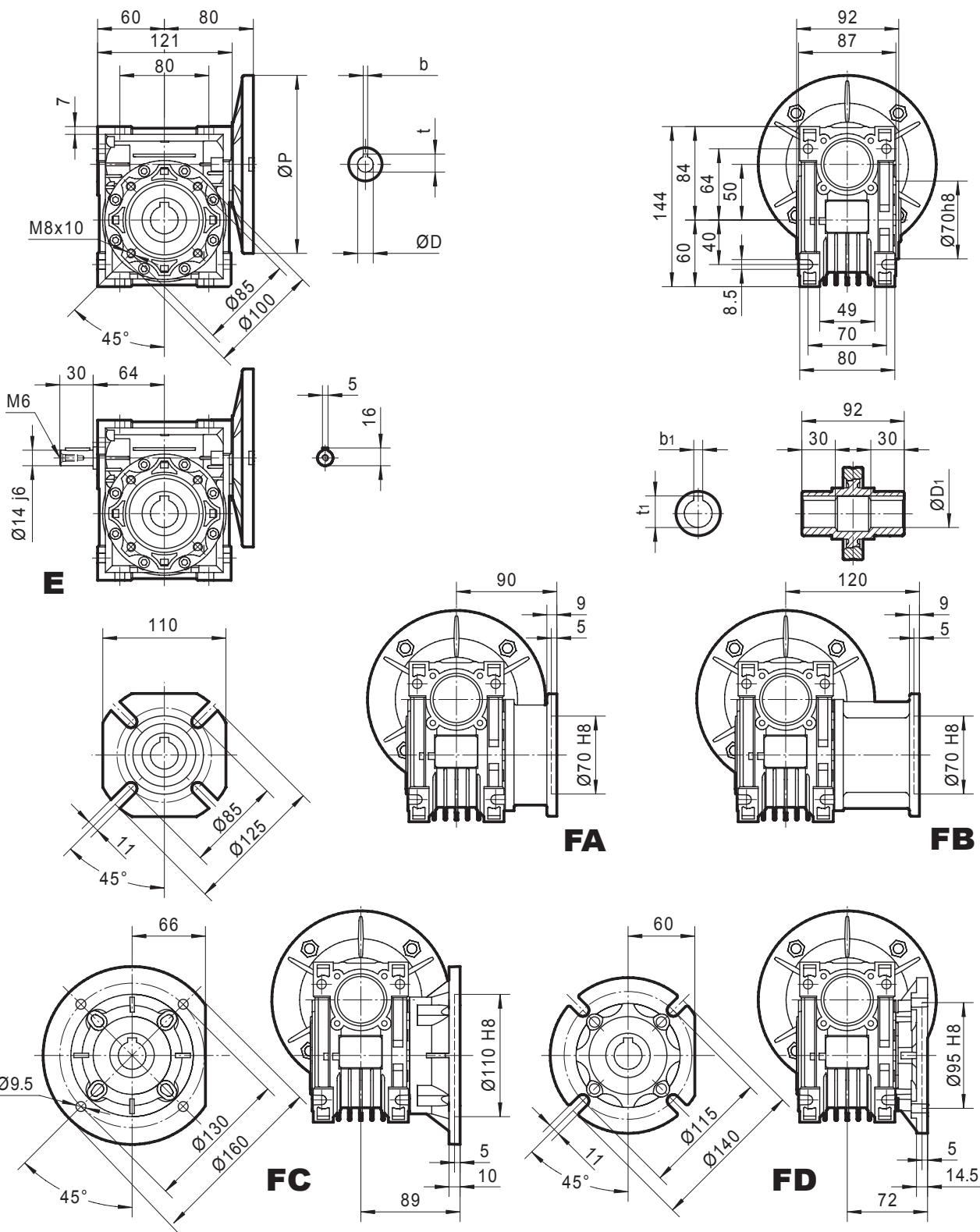

Peso senza motore ≈ 3.5 kg Weight without motor ≈ 3.5 kg

Per i dati dei motori (P, D, b, t), riferirsi alla tab. pag. 78

For the dimensions concerning the motor connection area (P, D, b, t) please refer to the table shown at page 78.

ØD1 H8	b1	t1
Ø25	8	28.3
Ø24*	8*	27.3*

(*) Modello non standard
(*) Nonstandard model

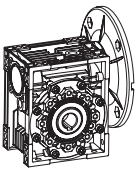

DIMENSIONI MRDV – MRDV SERIES DIMENSIONS

MRDV 063

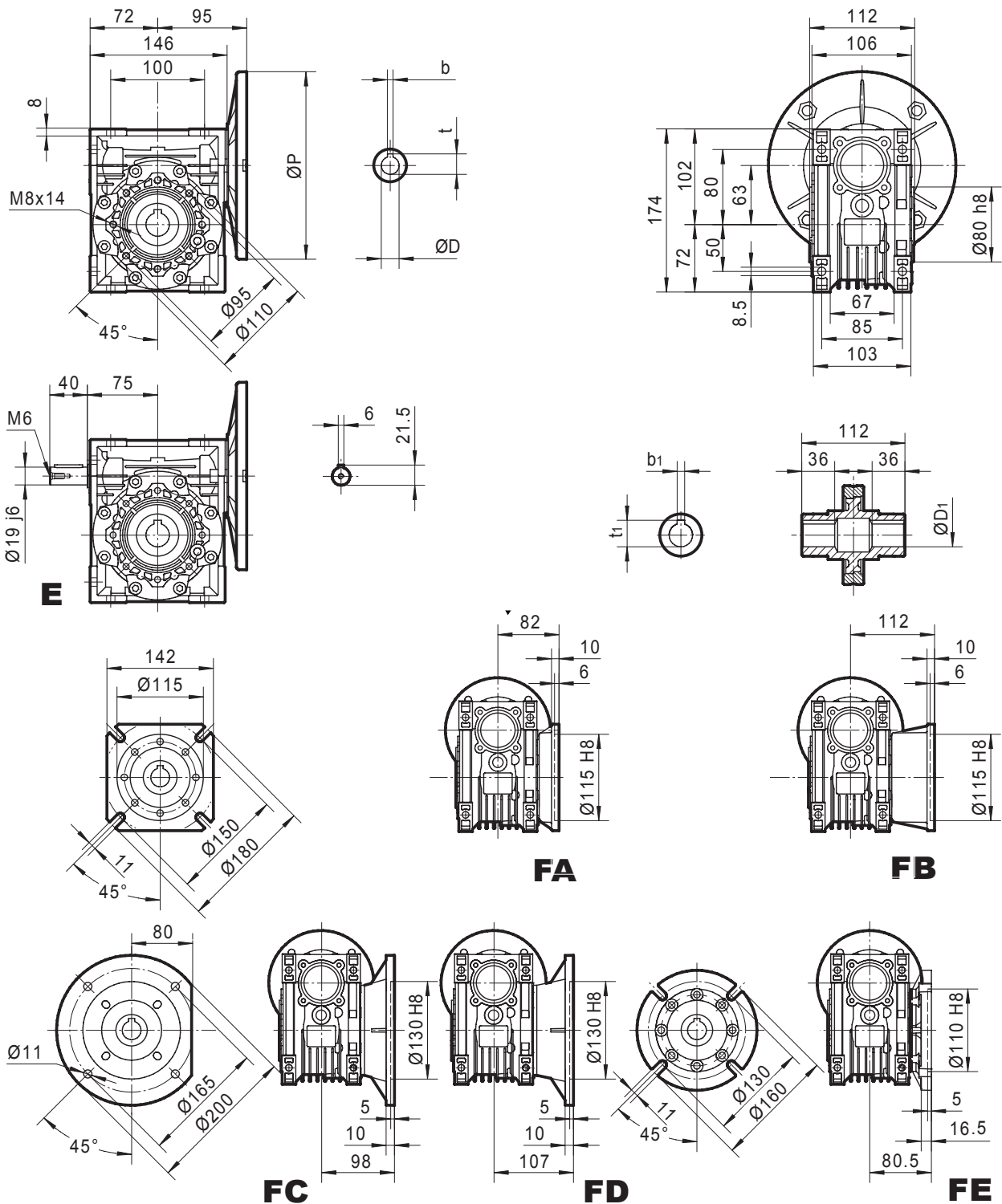

Peso senza motore ≈ 6.2 kg Weight without motor ≈ 6.2 kg

Per i dati dei motori (P, D, b, t), riferirsi alla tab. a pag. 78

For the dimensions concerning the motor connection area (P, D, b, t) please refer to the table shown at page 78.

Albero uscita Output size		
ØD ₁ H8	b ₁	t ₁
Ø25	8	28.3
Ø28*	8*	31.3*

(*) Modello non standard

(*) Nonstandard model

DIMENSIONI MRDV - NMRV SERIES DIMENSIONS

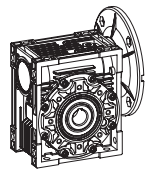

MRDV 075

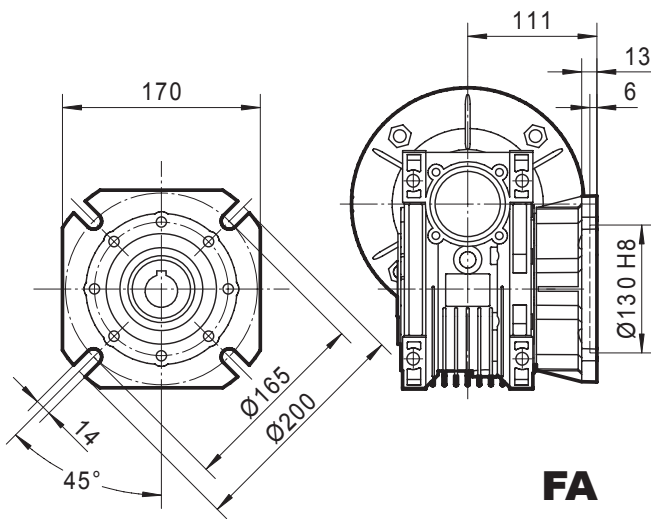
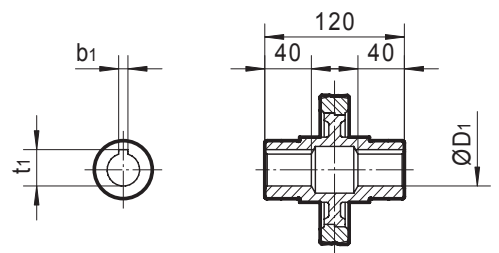
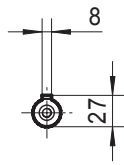
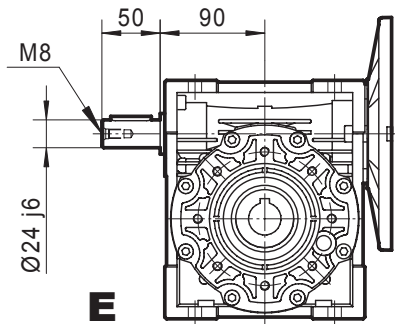
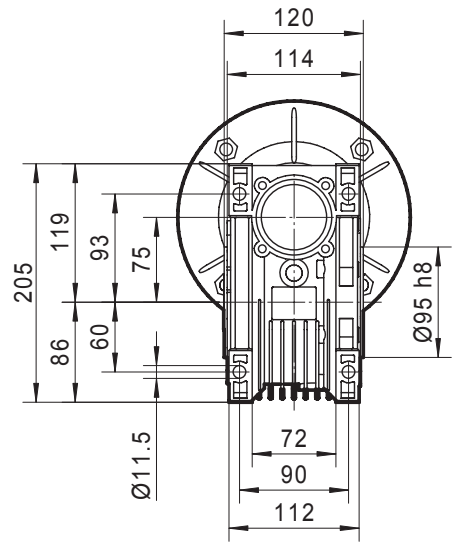
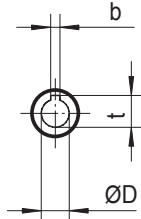
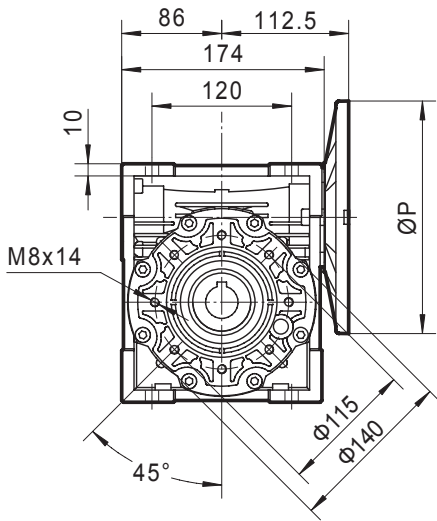

FA

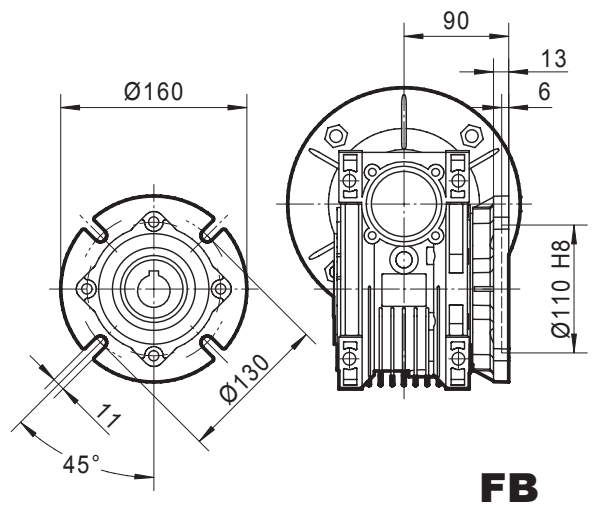

FB

Peso senza motore ≈ 9 kg Weight without motor ≈ 9 kg
er i dati dei motori (P, D, b, t), riferirsi alla tab. a pag. 78

For the dimensions concerning the motor connection area (P, D, b, t) please refer to the table shown at page 78.

Albero uscita - Output size		
ØD ₁ H8	b ₁	t ₁
Ø28	8	31.3
Ø35 *	10*	38.3 *

(*) Modello non standard
 (*) Nonstandard model

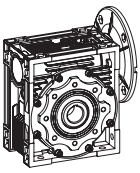

DIMENSIONI MRDV – MRDV SERIES DIMENSIONS

MRDV 090

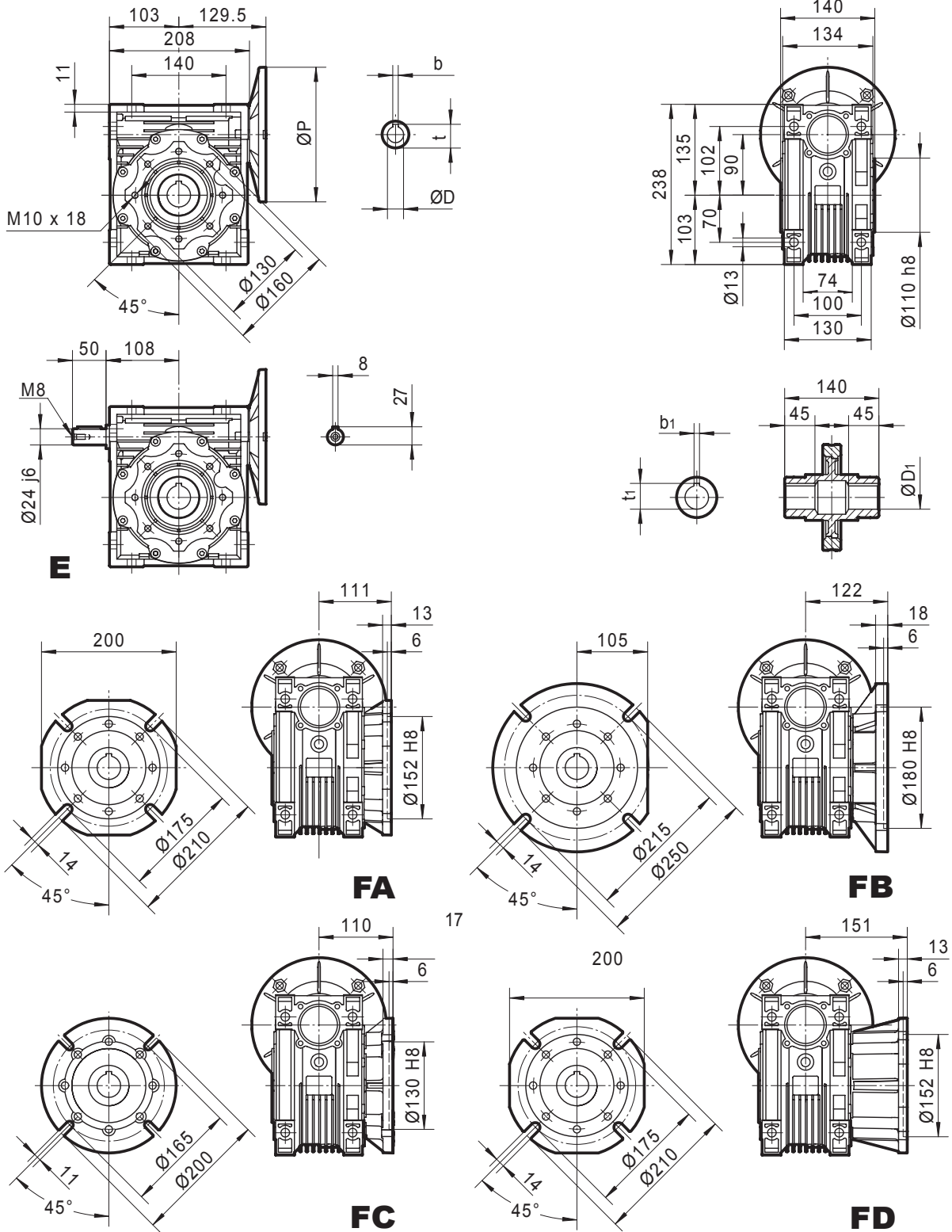

Peso senza motore ≈ 13 kg Weight without motor ≈ 13 kg
Per i dati dei motori (P, D, b, t) , riferirsi alla tab. pag.78
 For the dimensions concerning the motor connection area (P, D, b, t) please refer to the table shown at page 78.

ØD ₁ H8	b ₁	t ₁
Ø35	10	38.3
Ø38*	10*	41.3*

(*) **Modello non standard**
 (*) Nonstandard model

DIMENSIONI MRDV - MRDV SERIES DIMENSIONS

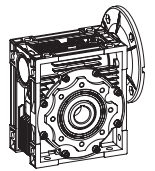

MRDV 110

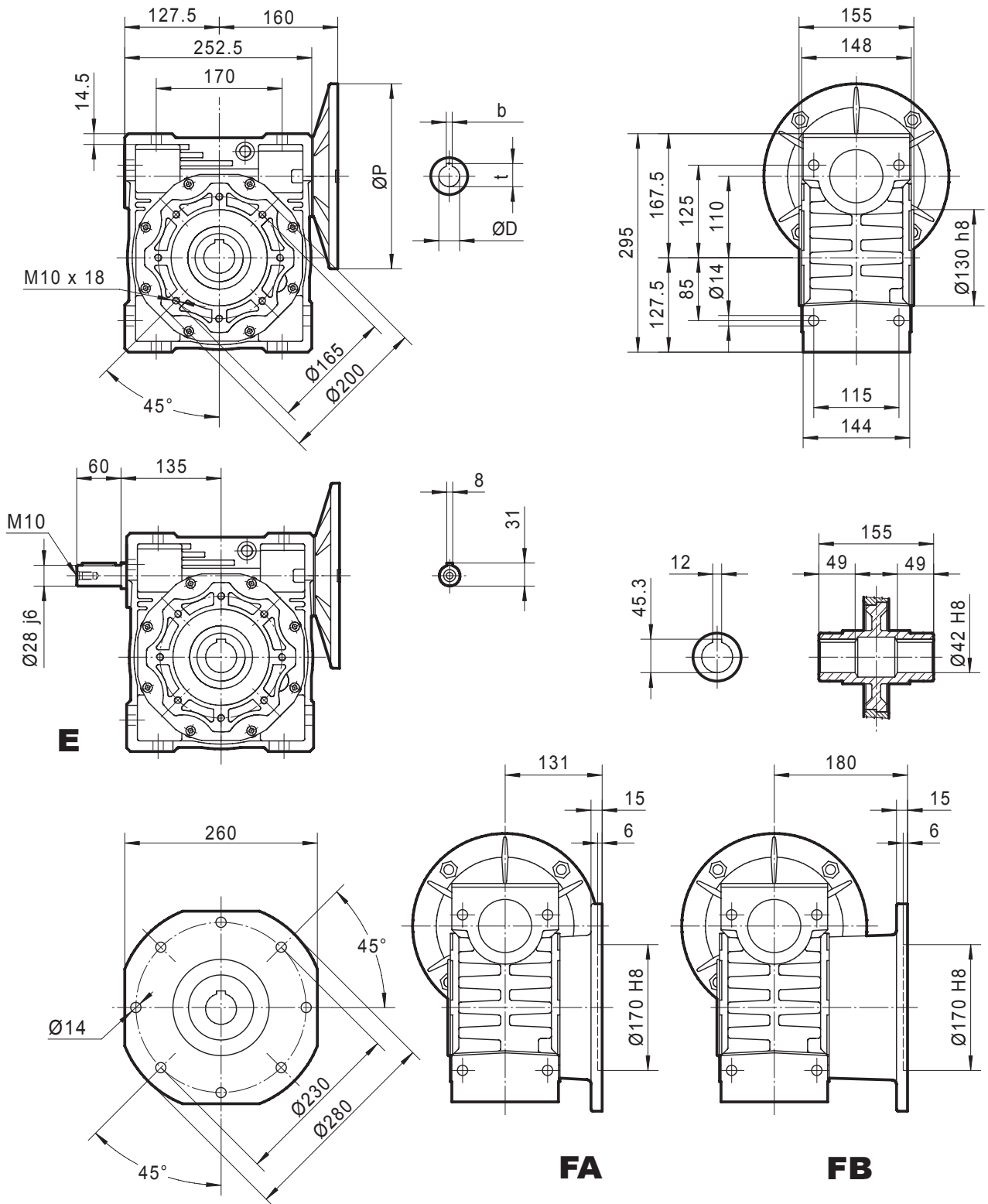

Peso senza motore ≈ 35 kg

Weight without motor ≈ 35 kg

Per i dati dei motori (P, D, b, t), riferirsi alla tab. pag. 78

For the dimensions concerning the motor connection area (P, D, b, t) please refer to the table shown at page 78.

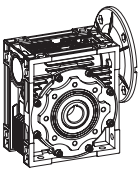

DIMENSIONI MRDV - MRDV SERIES DIMENSIONS

MRDV 130

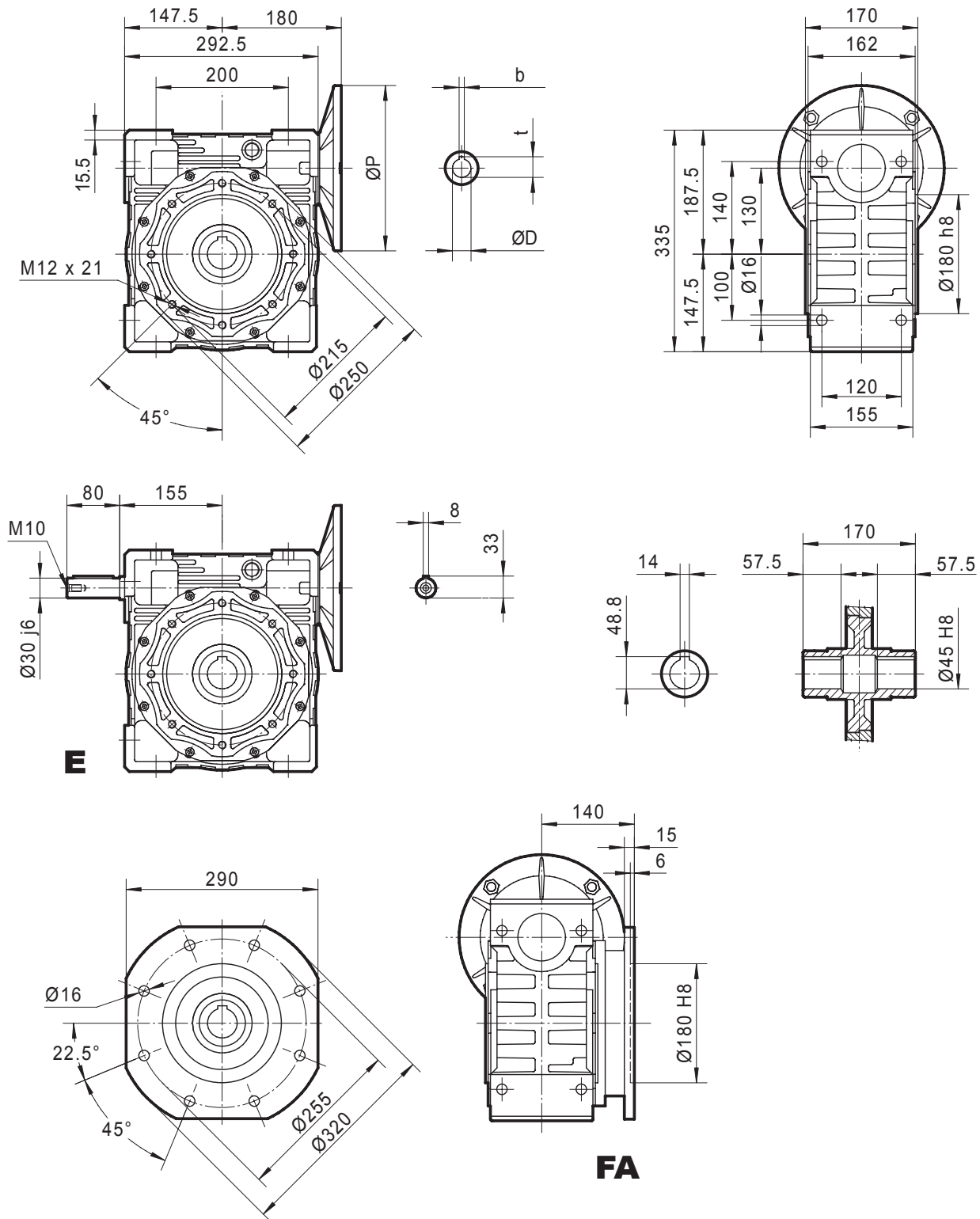

Peso senza motore ≈ 48 kg

Weight without motor ≈ 48 kg

Per i dati dei motori (P, D, b, t), riferirsi alla tab. a pag. 78

For the dimensions concerning the motor connection area (P, D, b, t) please refer to the table shown at page 78.