

- SERIE MRDB -
Riduttori Vite senza Fine
Worm Gearboxes

ELLE.GI SRL

*Organi di
Trasmissione*



12.1 FOTO RIDUTTORI / WORM GEARBOX PRODUCT PICTURE

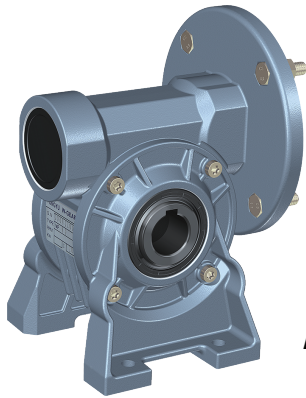

MRDB.A..

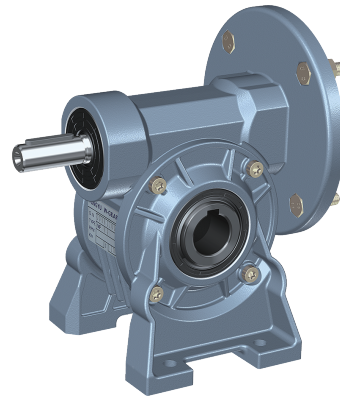

MRDB..A..E..

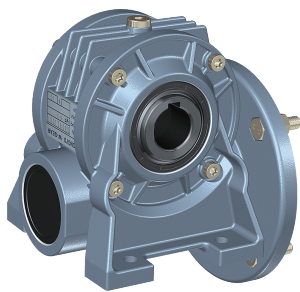

MRDB..N..

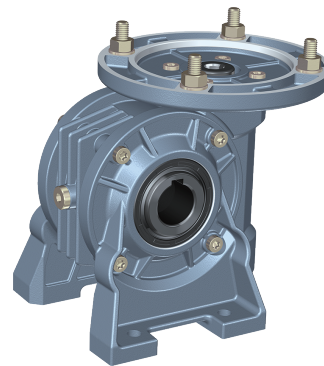

MRDB..V..

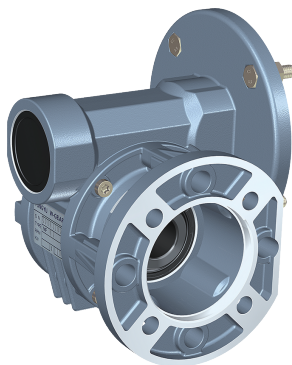

MRDB(FA)..

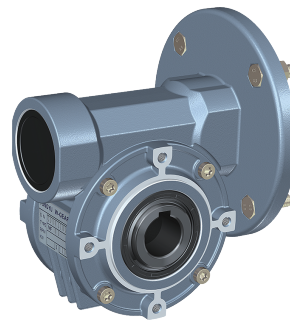

MRDB P..

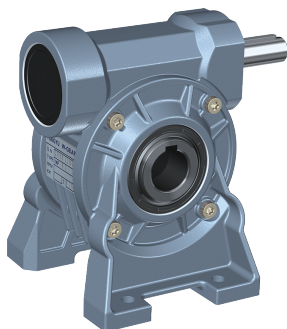

RDB..HS..

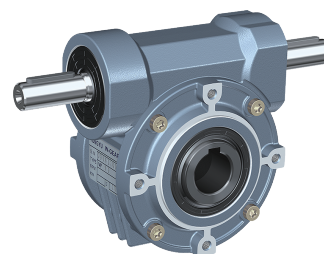

RDB..P.E..HS..

12.1.2 Illustrazione modelli / Model illuminate

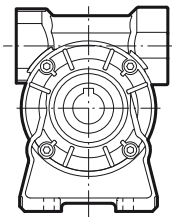
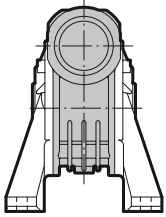

MRDB.. A..

Piedi Montati
Foot mounted

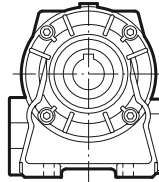
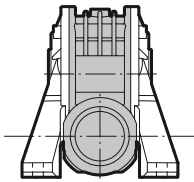

MRDB.. N..

Piedi Montati
Foot mounted

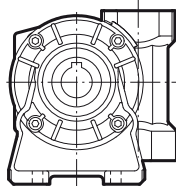
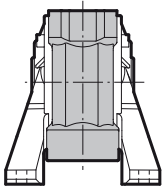

MRDB..V..

Piedi Montati
Foot mounted

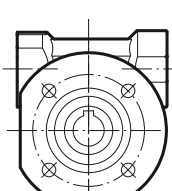
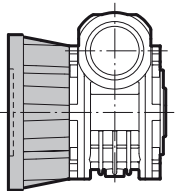

MRDB.. F..

Flangia in uscita standard
Standard output flange

MRDB.. F A..

Flangia in uscita più lunga
Extended output flange

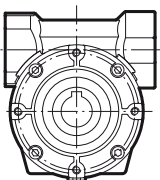
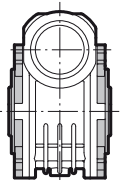

MRDB.. P..

Coperchio pendolare montato
Side cover for shaft mounting

12.2 ILLUSTRAZIONE MODELLO / MODEL ILLUMINATE

12.2.1 MRDB IDENTIFICAZIONE MODELLO / Worm gear units model illuminate

MRDB **30** **F** - **15** - **E** **SS1P** **71B5** **B3**
1
2
3
4
5
6
7
8

No	Note	Comments
1	Codice riduttore	Code of worm gear units
2	Interasse	Central distance of worm gear units (spec)
3	Versione riduttore 1). A Versione a piedi 2). N Versione a piedi 3). V Versione a piedi verticali 4). F(1/2) Flangia in uscita standard 5). FA(1/2) Flangia doppia in uscita 6). P Versione pendolare	Central distance of worm gear units (spec) 1). A : Foot mounted overdriven 2). N : Foot mounted underdriven 3). V : Foot mounted wormshaft vertical 4). F(1/2) : Standard output flange 5). FA(1/2) : Extended output flange 6). P : Side cover for shaft mounting
4	Rapporto riduttore (i = 7; 10; 14; 80; 100)	Speed ratio of reducer (i = 7; 10; 14; 80; 100)
5	1). Senza simbolo, vite semplice 2). E Doppia Vite	1). No mark means single extension worm shaft 2). E : Double extension worm shaft
6	1). Senza simbolo, albero cavo 2). SS(1/2) Singolo albero 3). DS Doppio albero	1). No mark means hole output 2). SS(1/2) : Single output shaft and position 3). DS : Double output shaft
7	1). IEC Flangia in uscita 2). HS : Albero in ingresso	1). IEC Output flange 2). HS : Shaft input
8	Posizione di montaggio	Installation position code



12.2.2 CMRDB/MRDV IDENTIFICAZIONE MODELLO / Combination worm gear units model illuminate

MRDB **30/44** **F** - **15** - **E** **SS1** **P71B5** **CW1**
1
2
3
4
5
6
7
8



No	说 明	Comments
1	Codice riduttore	Code of worm gear units
2	Interasse	Central distance of worm gear units (spec)
3	Versione riduttore 1). A : Versione a piedi 2). F(1/2) Flangia in uscita standard 3). FA(1/2) Flangia doppia in uscita 4). P Versione pendolare	Central distance of worm gear units (spec) 1). A : Foot mounted overdriven 2). F(1/2) : Standard output flange 3). FA(1/2) : Extended output flange 4). P : Side cover for shaft mounting
4	Rapporto riduttore (i = 240; 245; 315)	Speed ratio of reducer (i = 240; 245; 315)
5	1). Senza simbolo, vite semplice 2). E Doppia Vite	1). No mark means single extension worm shaft 2). E : Double extension worm shaft
6	1). Senza simbolo, albero cavo 2). SS(1/2) Singolo albero 3). DS Doppio albero	1). No mark means hole output 2). SS(1/2) : Single output shaft and position 3). DS : Double output shaft
7	1). IEC Flangia in uscita 2). HS : Albero in ingresso	1). IEC Output flange 2). HS : Shaft input
8	Posizione di montaggio	Installation position code

12.3 TABELLA SELEZIONE RIDUTTORI / GEAR UNIT SELECTION TABLES

12.3.1 MRDB ..P(IEC).. Prestazioni / Performance parameter

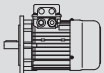

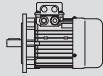
P_{1n} [kW]	n_2 [r/min]	M_{2n} [Nm]	i	F_{r2} [N]	f_s			Page							
0.06	19.3	14	70	1600	1.1	MRDB30	56B5/B14	5614	93						
	22.5	13	60	1600	1.5										
	34	10	40	1650	1.9										
	45	8	30	1340	2.5										
	68	6	20	1180	2.9										
	90	5	15	1080	3.7										
	135	3	10	950	4.7										
	193	2	7	840	6.4										
	2.4	74	560	2500	0.8	MRDB30/44	56B5/B14	5614	100						
		3.2	62	420	2500					1.0					
		3.9	53	350	2500					1.1					
		5.5	42	245	2500					1.4					
		2	116	720	3450					0.8	MRDB30/49	56B5/B14	5614	100	
			2.5	85	540					3450					1.1
			3.2	73	420					3450					1.3
4.3	53		315	3450	1.8										
5.6	45		240	3450	2.1										
0.09	22.5	19	60	1600	1.0	MRDB30	56B5/B14	5624	93						
	34	15	40	1410	1.3										
	45	12	30	1290	1.6										
	68	9	20	1140	2.0										
	90	7	15	1050	2.5										
	135	5	10	920	3.1										
	193	4	7	820	4.3										
	22	22	40	1560	0.9	MRDB30	63B5/B14	6316	93						
		29.3	18	30	1440					1.2					
		44	14	20	1230					1.5					
		59	11	15	1170					1.9					
		88	8	10	1050					2.3					
		126	6	7	920					3.2					
		3.9	80	350	2500					0.7	MRDB30/44	56B5/B14	5624	99	
	5.5		62	245	2500	1.0									
	12.6	38	70	2300	0.8	MRDB44	63B5/B14	6316	95						
		14.7	33	60	2300					1.2					
		19.1	28	46	2300					1.4					
		25.1	23	35	2300					1.7					
		31	19	28	2300					2.0					
		44	15	20	2300					2.6					
		3.2	110	420	3450					0.9	MRDB30/49	56B5/B14	5624	100	
	4.3		80	315	3450	1.2									
	5.6		69	240	3450	1.4									
	8.8	41	100	3300	1.3	MRDB49	63B5/B14	6316	97						
		11.0	37	80	3300					1.6					
		12.6	34	70	3300					1.8					
14.7		31	60	3300	2.1										
19.6		26	45	3300	2.7										
24.4		22	36	3300	3.4										
0.12		138	7	20	840					2.1	MRDB30	56B5/B14	5622	93	
	275	4	10	740	3.4										
	393	3	7	660	4.7										
	33	21	40	1360	0.9	MRDB30	63B5/B14	6314	93						
		44	17	30	1250					1.2					
		66	13	20	1110					1.4					

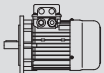

P_{1n} [kW]	n_2 [r/min]	M_{2n} [Nm]	i	F_{r2} [N]	f_s			Page							
0.12	87	10	15	1020	1.8	MRDB30	63B5/B14	6314	93						
	131	7	10	900	2.3										
	187	5	7	810	3.1										
		29	24	30	1360	0.9	MRDB30	63B5/B14	6326	93					
		44	18	20	1250	1.1									
		58	15	15	1130	1.4									
		87	10	10	1020	1.7									
		124	8	7	900	2.4									
			18.7	34	70	3300					0.9	MRDB44	63B5/B14	6314	95
	21.8		30	60	2300	1.3									
	28.5		25	46	2300	1.6									
	37		21	35	2300	1.9									
	47		17	28	2300	2.2									
	66		13	20	2100	2.9									
	94		10	14	1870	2.9									
			14.5	42	60	2300	1.1	MRDB44	63B5/B14	6326	95				
		19	36	46	2300	1.4									
		25	30	35	2300	1.7									
		31	25	28	2300	2.0									
		44	19	20	2300	2.3									
		62	14	14	2150	2.7									
	4.2	110	315	3450	0.9	MRDB30/49	63B5/B14	6314	100						
	5.5	94	240	3450	1.0										
	13.1	42	100	3150	1.2	MRDB49	63B5/B14	6314	97						
	16.4	36	80	3150	1.5										
	18.7	34	70	3150	1.6										
	21.8	30	60	3150	1.9										
	29.1	25	45	3040	2.6										
	36	21	36	2830	3.3										
	8.7	55	100	3300	0.9					MRDB49	63B5/B14	6326	97		
10.9	50	80	3300	1.2											
0.18	90	13	30	1020	1.1	MRDB30	63B5/B14	6312	93						
	135	10	20	900	1.4										
	180	8	15	800	1.8										
	270	5	10	710	2.2										
	386	4	7	640	3.1										
		66	19	20	1040	1.0	MRDB30	63B5/B14	6324	93					
		88	15	15	960	1.2									
		132	11	10	860	1.5									
		189	8	7	770	2.1									
		45	24	60	2300	1.2	MRDB44	63B5/B14	6312	95					
		59	20	46	2190	1.4									
		77	16	35	1970	1.8									
		96	14	28	1770	2.1									
		135	10	20	1590	2.8									
		193	7	14	1470	2.9									
		22	45	60	2300	0.9	MRDB44	63B5/B14	6324	95					
		29	37	46	2500	1.1									
		38	31	35	2430	1.3									
		47	26	28	2270	1.5									
		66	20	20	2040	1.9									
		94	15	14	1830	2.0									
		132	11	10	1640	2.7									
			26	43	35	2340					1.1	MRDB44	71B5/B14	7116	95
			32	36	28	2290					1.4				
	45		28	20	2050	1.6									
	64		21	14	1830	1.9									
	90		16	10	1650	2.5									



P_{1n} [kW]	n_2 [r/min]	M_{2n} [Nm]	i	F_{r2} [N]	f_s				Page
0.18	16.5	54	80	3150	1.0	MRDB49	63B5/B14	6324	97
	18.9	50	70	3150	1.1				
	22	45	60	3150	1.3				
	29.3	37	45	2300	1.8				
	37	31	36	2760	2.2				
	47	26	28	2560	2.9				
	55	23	24	2430	2.7				
	73	19	18	2230	3.2				
	15	61	60	3000	1.1	MRDB49	71B5/B14	7116	97
	20	52	45	2790	1.4				
	25	43	36	2650	1.7				
	32	36	28	2450	2.3				
	0.25	135	14	20	840		MRDB30	63B5/B14	6322
180		11	15	780					
270		7	10	690					
77		23	35	1930	1.3	MRDB44	63B5/B14	6322	95
96		19	28	1730	1.5				
135		14	20	1550	2.0				
193		10	14	1400	2.1				
270		8	10	1300	2.9				
38		43	35	2300	0.9				
47		36	28	2190	1.1				
66		28	20	1970	1.4				
94		21	14	1770	1.4				
132		15	10	1590	1.9				
189		11	7	1420	2.7				
32		50	28	2300	1.0	MRDB44	71B5/B14	7126	95
45		39	20	2190	1.1				
64		29	14	1980	1.3				
90		22	10	1780	1.8				
129		16	7	1590	2.5				
39		38	70	2650	1.1				
45		34	60	2500	1.3				
60		28	45	2350	1.8				
75		23	36	2230	2.2				
96		19	28	2070	2.9				
113		17	24	1930	2.8				
22		63	60	3100	0.9	MRDB49	71B5/B14	7114	97
29		51	45	2810	1.3				
37		44	36	2670	1.6				
47		36	28	2480	2.1				
55		33	24	2360	1.9				
73		26	18	2170	2.3				
94		21	14	2010	3.2				
20	72	45	3150	1.0	MRDB49				
25	60	36	3150	1.2					
32	51	28	3150	1.6					
38	46	24	2600	1.5					
50	36	18	2460	1.9					
64	29	14	2260	2.4					
90	22	10	2040	2.9					
0.37	79	33	35	1860	0.9	MRDB49	71B5/B14	7112	95
	98	27	28	1720	1.1				
	138	21	20	1570	1.4				
	196	15	14	1400	1.5				
	275	11	10	1260	2.0				
	393	8	7	1120	2.7				

P_{1n} [kW]	n_2 [r/min]	M_{2n} [Nm]	i	F_{r2} [N]	f_s			Page	
0.37	69	40	20	1870	1.0	MRDB44	71B5/B14	7124	95
	98	29	14	1690	1.0				
	137	22	10	1520	1.3				
	196	16	7	1360	1.9				
	61	40	45	2270	1.2	MRDB49	71B5/B14	7112	97
	76	34	36	2180	1.5				
	98	28	28	2020	2.0				
	115	25	24	1880	1.9				
	153	19	18	1720	2.3				
	30	73	45	2680	0.9	MRDB49	71B5/B14	7124	97
	38	62	36	2530	1.1				
	49	51	28	2360	1.4				
	57	46	24	2250	1.4				
	76	37	18	2080	1.6				
	98	29	14	1940	2.2				
	137	22	10	1750	2.7				
196	16	7	1570	3.4					
38	67	24	2350	1.0	MRDB49	80B5/B14	8016	97	
51	53	18	2240	1.3					
65	43	14	2070	1.7					
91	32	10	1930	2.0					
130	23	7	1740	2.6					
0.55	141	30	20	1490	1.0	MRDB44	71B5/B14	7122	95
	201	22	14	1350	1.0				
	281	16	10	1210	1.4				
	401	12	7	1080	1.9				
	78	49	36	2090	1.1	MRDB49	71B5/B14	7122	97
	100	40	28	1960	1.4				
	117	36	24	1800	1.3				
	156	28	18	1650	1.6				
	201	22	14	1420	2.2				
	281	16	10	1390	2.7				
	401	12	7	1250	3.5				
	49	76	28	2170	1.0	MRDB49	80B5/B14	8014	97
	58	69	24	2080	0.9				
	77	54	18	1930	1.1				
	99	43	14	1810	1.5				
	138	32	10	1650	1.8				
197	23	7	1480	2.3					
66	63	14	1960	1.1	MRDB49	80B5/B14	8026	97	
92	47	10	1800	1.4					
131	34	7	1660	1.8					
0.75	117	49	24	1710	1.0	MRDB49	80B5/B14	8012	97
	156	38	18	1580	1.2				
	200	30	14	1480	1.6				
	280	22	10	1340	2.0				
	400	16	7	1200	2.6				
	100	58	14	1690	1.1	MRDB49	80B5/B14	8024	97
	140	43	10	1540	1.4				
200	31	7	1400	1.7					
1.1	200	45	14	1370	1.1	MRDB49	80B5/B14	8022	97
	280	33	10	1250	1.3				
	400	23	7	1130	1.8				



12.3.2 MRDB..HS.. Prestazioni / Performance parameter

M_{2n} [Nm]	n_1 [r/min]	i	P_{1n} [kW]	n_2 [r/min]	F_{r2} [N]	F_{r1} [N]		Page 
12	2800	7	0.58	400	510	120	MRDB30	101
12	2800	10	0.41	280	620	70		
14	2800	15	0.34	187	720	—		
14	2800	20	0.26	140	820	—		
15	2800	30	0.21	93	960	—		
14	2800	40	0.16	70	1090	—		
14	2800	60	0.12	47	1270	—		
11	2800	70	0.08	40	1380	—		
16	1400	7	0.41	200	630	140	MRDB30	101
16	1400	10	0.30	140	770	80		
18	1400	15	0.24	93	910	—		
18	1400	20	0.19	70	1030	—		
20	1400	30	0.15	47	1200	—		
19	1400	40	0.12	35	1360	—		
19	1400	60	0.09	23.3	1590	—		
15	1400	70	0.07	20	1600	—		
18	900	7	0.30	129	730	150	MRDB30	101
18	900	10	0.22	90	900	150		
20	900	15	0.17	60	1060	—		
20	900	20	0.14	45	1200	—		
22	900	30	0.12	30	1400	—		
20	900	40	0.09	23	1590	—		
20	900	60	0.07	15	1650	—		
17	900	70	0.05	13	1700	—		
20	500	7	0.19	71	920	150	MRDB30	101
20	500	10	0.14	50	1120	150		
22	500	15	0.11	33	1320	150		
22	500	20	0.09	25	1490	150		
24	500	30	0.07	16.7	1700	—		
22	500	40	0.06	12.5	1700	—		
22	500	60	0.05	8.3	1700	—		
19	500	70	0.04	7	1700	—		

M_{2n} [Nm]	n_1 [r/min]	i	P_{1n} [kW]	n_2 [r/min]	F_{R2} [N]	F_{R1} [N]		Page 		
22	2800	7	1.1	400	950	220	MRDB44	101		
22	2800	10	0.74	280	1150	220				
22	2800	14	0.55	200	1340	220				
29	2800	20	0.52	140	1490	220				
29	2800	28	0.40	100	1710	220				
29	2800	35	0.33	80	1870	220				
29	2800	46	0.27	61	2080	220				
29	2800	60	0.22	47	2290	220				
22	2800	70	0.15	40	2300	220				
21	2800	100	0.11	28	2300	220				
29	1400	7	0.71	200	1180	220	MRDB44	101		
29	1400	10	0.51	140	1430	220				
29	1400	14	0.37	100	1680	220				
39	1400	20	0.37	70	1860	220				
39	1400	28	0.29	50	2140	220				
39	1400	35	0.25	40	2300	220				
39	1400	46	0.19	30	2300	220				
39	1400	60	0.16	23.3	2300	220				
29	1400	70	0.11	20	2300	220				
28	1400	100	0.09	14	2300	220				
39	900	7	0.63	129	1300	220			MRDB44	101
39	900	10	0.45	90	1610	220				
39	900	14	0.34	64	1890	220				
45	900	20	0.29	45	2160	220				
49	900	28	0.24	32	2300	220				
49	900	35	0.20	25.7	2300	220				
49	900	46	0.17	19.6	2300	220				
45	900	60	0.13	15	2300	200				
39	900	70	0.10	12.9	2300	220				
30	900	100	0.06	9	2300	220				
45	500	7	0.41	71	1610	220	MRDB44	101		
45	500	10	0.29	50	1980	220				
50	500	14	0.25	36	2280	220				
50	500	20	0.18	25	2500	220				
55	500	28	0.16	17.9	2500	220				
55	500	35	0.14	14.3	2500	220				
50	500	46	0.10	10.9	2500	220				
50	500	60	0.09	8.3	2500	220				
45	500	70	0.07	7.1	2500	220				
32	500	100	0.04	5	2500	220				

M_{2n} [Nm]	n_1 [r/min]	i	P_{1n} [kW]	n_2 [r/min]	F_{R2} [N]	F_{R1} [N]		Page 
41	2800	7	2	400	950	400	MRDB49	101
44	2800	10	1.5	280	1140	400		
49	2800	14	1.2	200	1310	400		
44	2800	18	0.87	156	1520	400		
47	2800	24	0.73	117	1670	400		
56	2800	28	0.78	100	1740	400		
52	2800	36	0.59	78	1970	400		
49	2800	45	0.46	62	2180	400		
44	2800	60	0.34	47	2480	400		
41	2800	70	0.28	40	2650	400		
41	2800	80	0.25	35	2780	400		
37	2800	100	0.20	28	3050	400		
54	1400	7	1.3	200	1170	400	MRDB49	101
59	1400	10	1.0	140	1410	400		
65	1400	14	0.90	100	1630	400		
59	1400	18	0.60	78	1890	400		
63	1400	24	0.50	58	2110	400		
74	1400	28	0.55	50	2170	400	MRDB49	101
69	1400	36	0.42	39	2460	400		
65	1400	45	0.33	31	2725	400		
59	1400	60	0.25	23.3	3100	400		
55	1400	70	0.21	20	3150	400		
54	1400	80	0.19	17.5	3150	400		
49	1400	100	0.13	14	3150	400		
61	900	7	0.97	129	1370	400		
64	900	10	0.75	90	1670	400		
71	900	14	0.61	64	1920	400		
68	900	18	0.47	50	2190	400		
68	900	24	0.36	38	2480	400		
82	900	28	0.41	32	2540	400		
75	900	36	0.31	25	2880	400		
71	900	45	0.25	20	3190	400		
64	900	60	0.19	15	3300	400		
60	900	70	0.16	12.9	3300	400		
58	900	80	0.14	11.3	3300	400		
52	900	100	0.11	9	3300	400		
74	500	7	0.67	71	1670	400	MRDB49	101
74	500	10	0.49	50	2060	400		
78	500	14	0.39	36	2400	400		
74	500	18	0.30	27.8	2730	400		
74	500	24	0.24	20.8	3090	400		
88	500	28	0.26	17.9	3180	400		
80	500	36	0.20	13.9	3450	400		
78	500	45	0.17	11.1	3450	400		
69	500	60	0.12	8.3	3450	400		
69	500	70	0.11	7.1	3450	400		
59	500	80	0.09	6.3	3450	400		
59	500	100	0.08	5	3450	400		

12.3.3 MRDB/MRDB Prestazioni / *Performance parameter*

M_{2n} [Nm]	n_1 [r/min]	i	P_{1n} [kW]	n_2 [r/min]	F_{R2} [N]	F_{R1} [N]		Page 
60	1400	245	0.09	5.7	2500	140	MRDB30/44	102
60	1400	350	0.07	4.0	2500	80		
60	1400	420	0.06	3.3	2500	—		
60	1400	560	0.05	2.5	2500	—		
60	1400	700	0.04	2.0	2500	—		
60	1400	840	0.04	1.7	2500	—		
60	1400	1120	0.03	1.3	2500	—		
60	1400	1680	0.02	0.83	2500	—		
60	1400	2100	0.02	0.67	2500	—		
70	900	245	0.07	3.7	2500	150	MRDB30/44	102
70	900	350	0.05	2.6	2500	150		
70	900	420	0.04	2.1	2500	—		
70	900	560	0.04	1.6	2500	—		
70	900	700	0.03	1.3	2500	—		
70	900	840	0.03	1.1	2500	—		
70	900	1120	0.02	0.8	2500	—		
70	900	1680	0.02	0.54	2500	—		
70	900	2100	0.02	0.43	2500	—		
95	1400	240	0.13	5.8	3450	80	MRDB30/49	102
95	1400	315	0.11	4.4	3450	140		
95	1400	420	0.08	3.3	3450	—		
95	1400	540	0.07	2.6	3450	—		
95	1400	720	0.05	1.9	3450	—		
95	1400	900	0.05	1.6	3450	—		
95	1400	1120	0.04	1.3	3450	—		
95	1400	1440	0.04	0.97	3450	—		
95	1400	2160	0.03	0.65	3450	—		
95	1400	2700	0.03	0.52	3450	—		
100	900	240	0.09	3.8	3450	150	MRDB30/49	102
100	900	315	0.07	2.9	3450	150		
100	900	420	0.06	2.1	3450	—		
100	900	540	0.05	1.7	3450	—		
100	900	720	0.04	1.3	3450	—		
100	900	900	0.04	1.0	3450	—		
100	900	1120	0.03	0.80	3450	—		
100	900	1440	0.03	0.63	3450	—		
100	900	2160	0.02	0.42	3450	—		
100	900	2700	0.02	0.33	3450	—		

12.4 DIMENSIONI / OUTLINE DIMENSION SHEET

12.4.1 MRDB.. Dimensioni / Outline dimension

MRDB30A..P(IEC)

Piedi / Input adapters

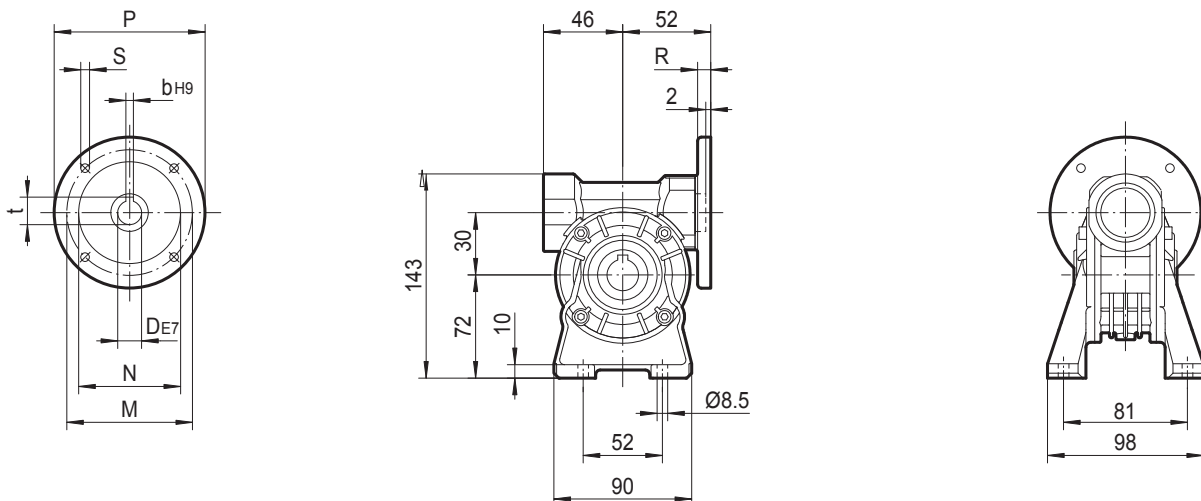

Dimensioni albero / Worm output shaft

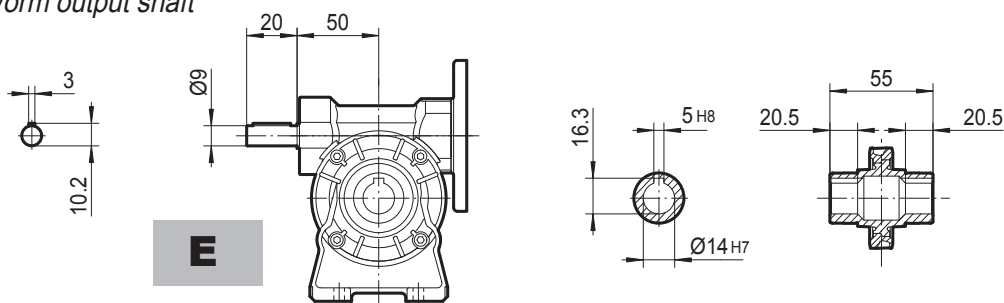

MRDB30N..

MRDB30V..

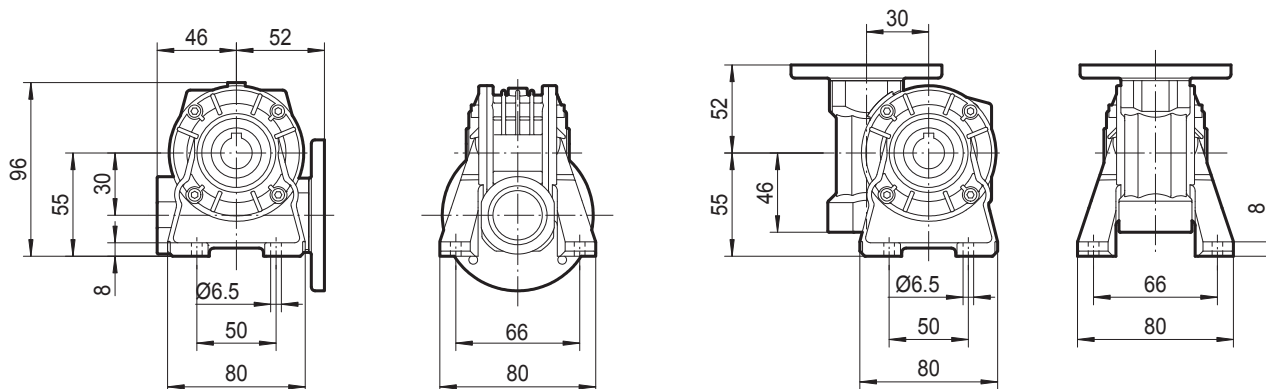

IEC	D _{E7}	b	t	P	M	N	R	S
56B5	9	3	10.4	120	100	80	7	7
56B14	9	3	10.4	80	65	50	7	5.5
63B5	11	4	12.8	140	115	95	8	9.5
63B14	11	4	12.8	90	75	60	7	5.5

MRDB 30P..P(IEC)

Piedi / Input adapters

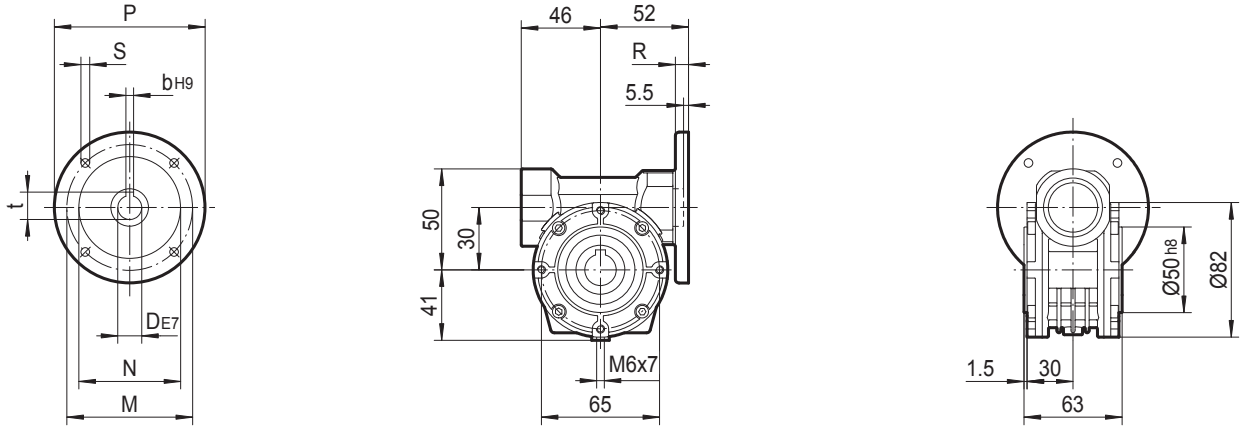

Dimensioni albero / Worm output shaft

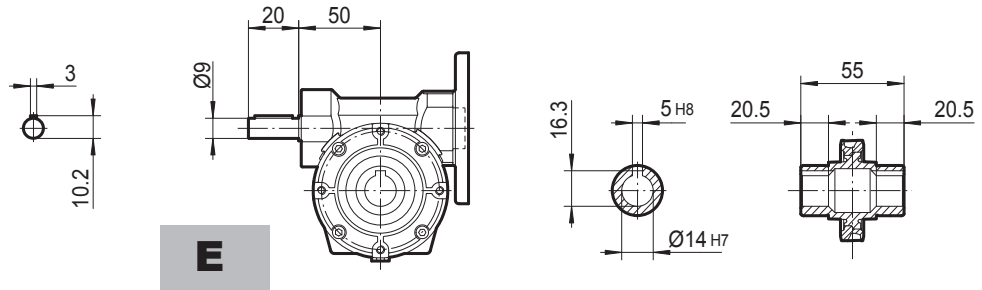

MRDB30F..

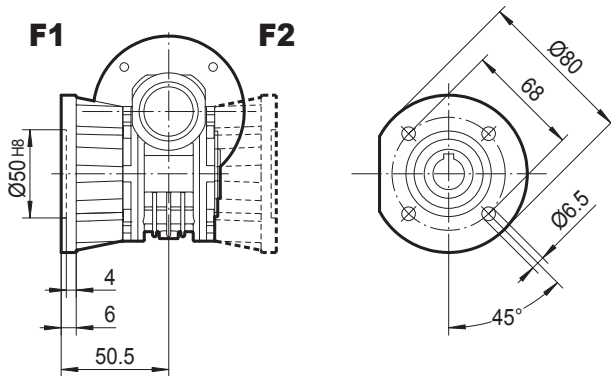

IEC	D _{E7}	b	t	P	M	N	R	S
56B5	9	3	10.4	120	100	80	7	7
56B14	9	3	10.4	80	65	50	7	5.5
63B5	11	4	12.8	140	115	95	8	9.5
63B14	11	4	12.8	90	75	60	7	5.5

MRDB44A.. P(IEC)

Piedi / Input adapters

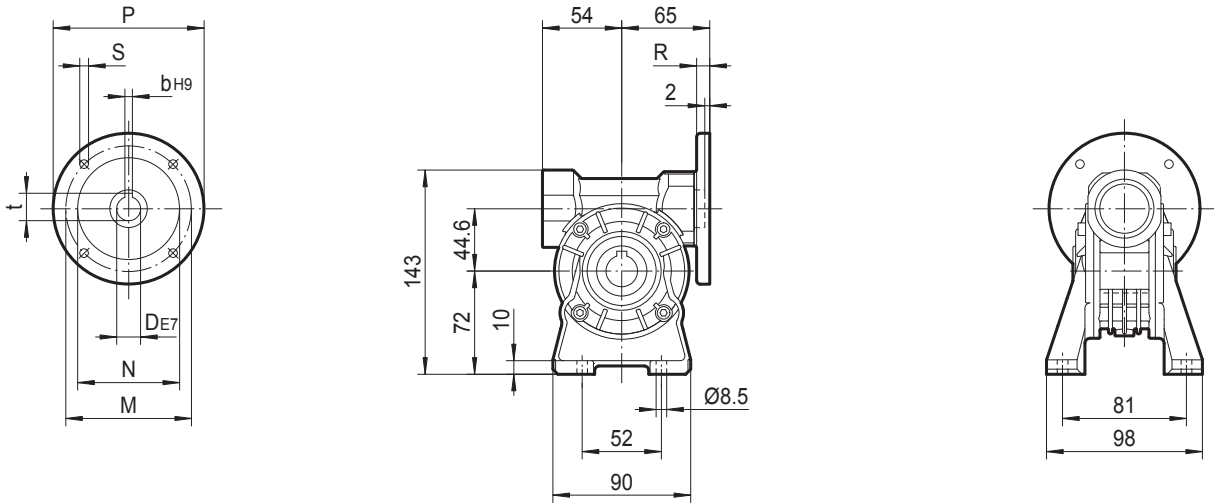

Dimensioni albero / Worm output shaft

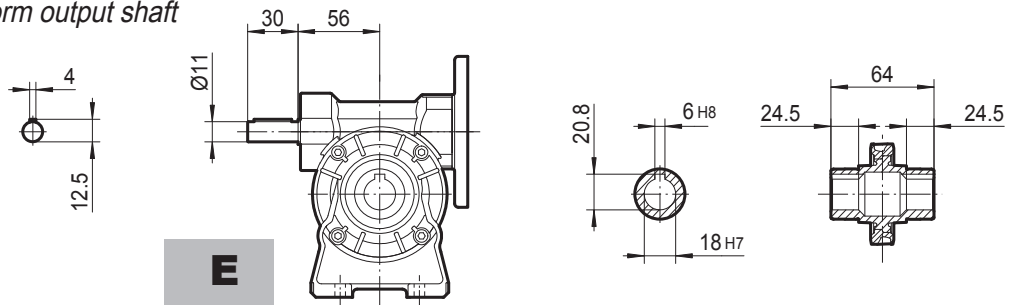

MRDB44N..

MRDB44V..

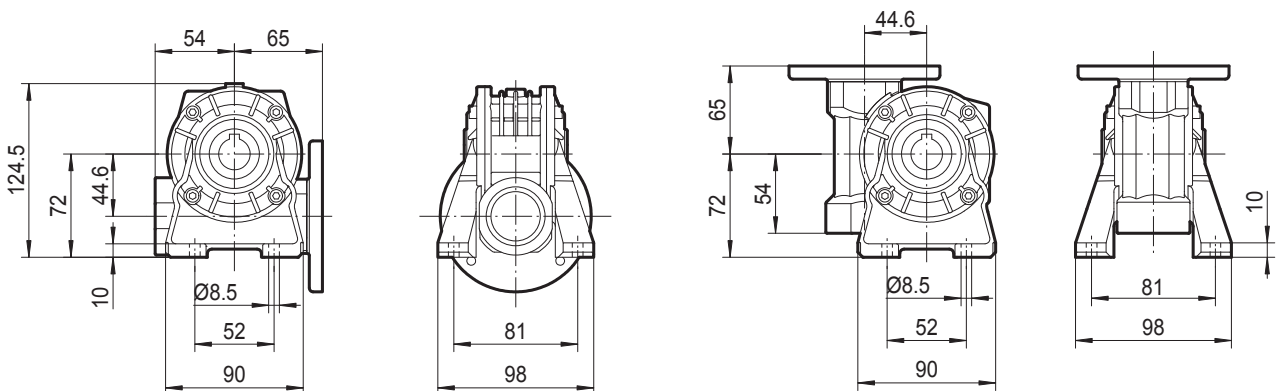

IEC	D _{E7}	b	t	P	M	N	R	S
63B5	11	4	12.8	140	115	95	10	9.5
63B14	11	4	12.8	90	75	60	8	5.5
71B5	14	5	16.3	160	130	110	10	9.5
71B14	14	5	16.3	105	85	70	10	7

MRDB44P..P(IEC)

Piedi / Input adapters

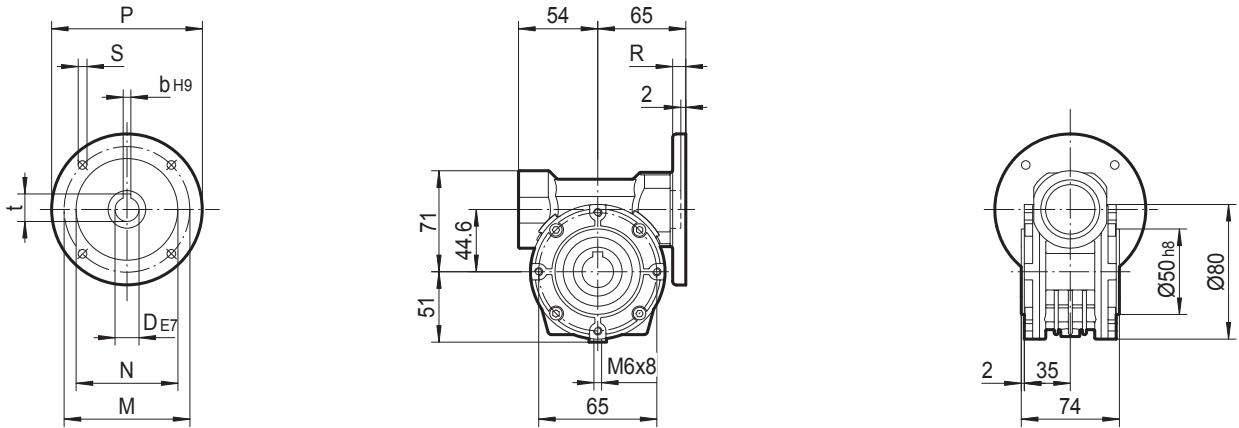

Dimensione albero / Worm output shaft

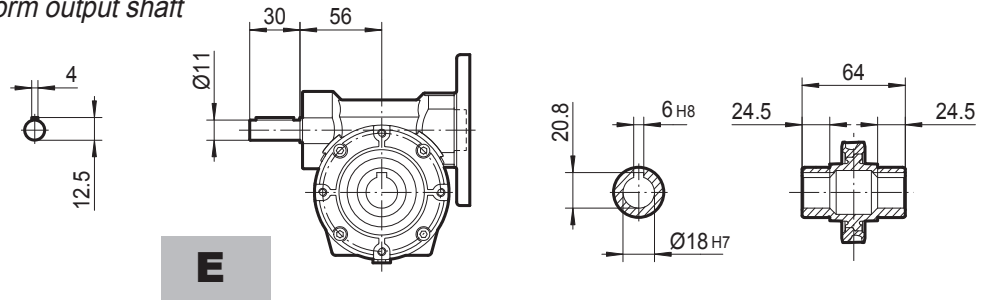

MRDB44F..

MRDB44FA..

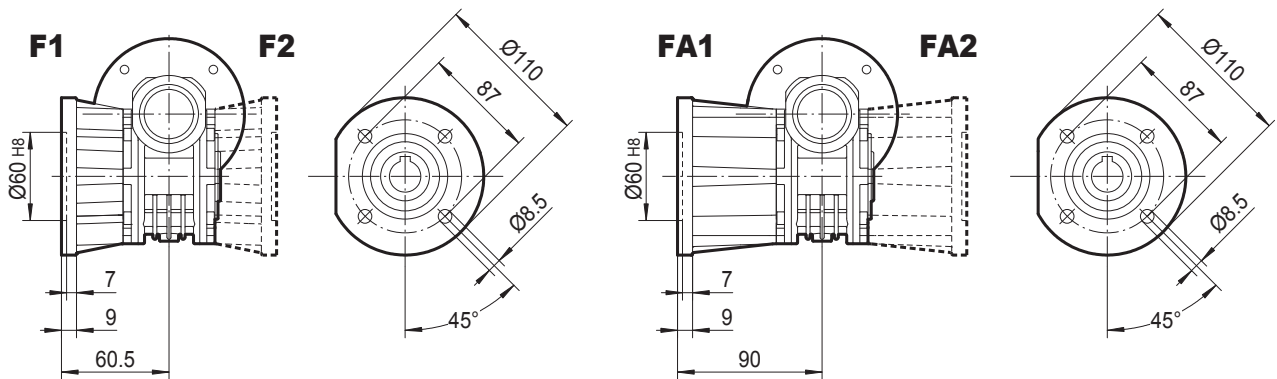

IEC	D E7	b	t	P	M	N	R	S
63B5	11	4	12.8	140	115	95	10	9.5
63B14	11	4	12.8	90	75	60	8	5.5
71B5	14	5	16.3	160	130	110	10	9.5
71B14	14	5	16.3	105	85	70	10	7

MRDV49A..P(IEC)

Piedi / Input adapters

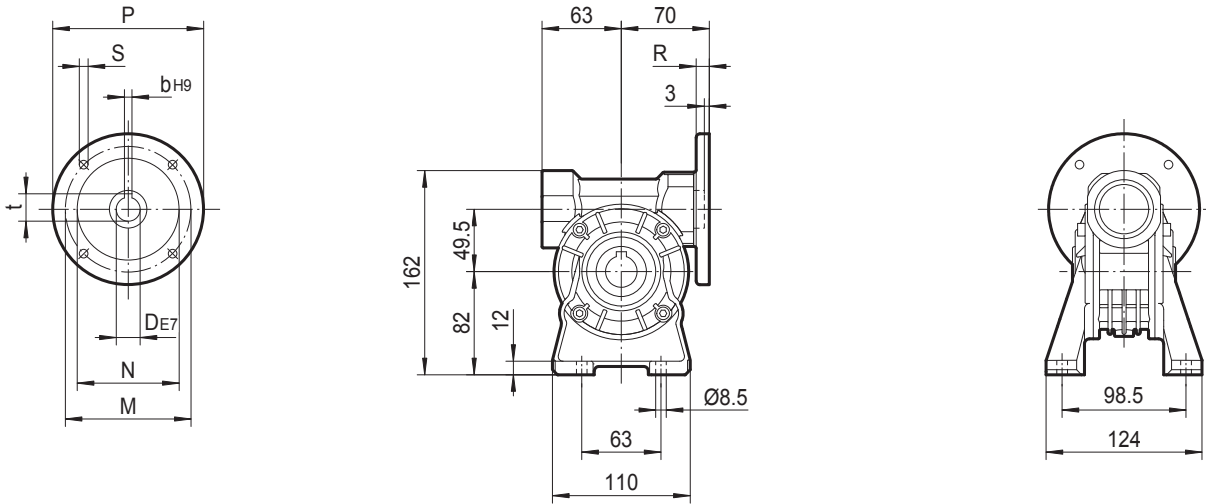

Dimensioni albero / Worm output shaft

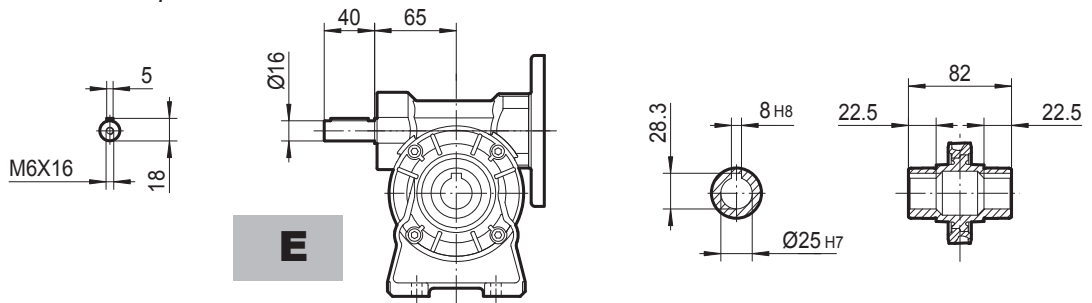

MRDB49N..

MRDB49V..

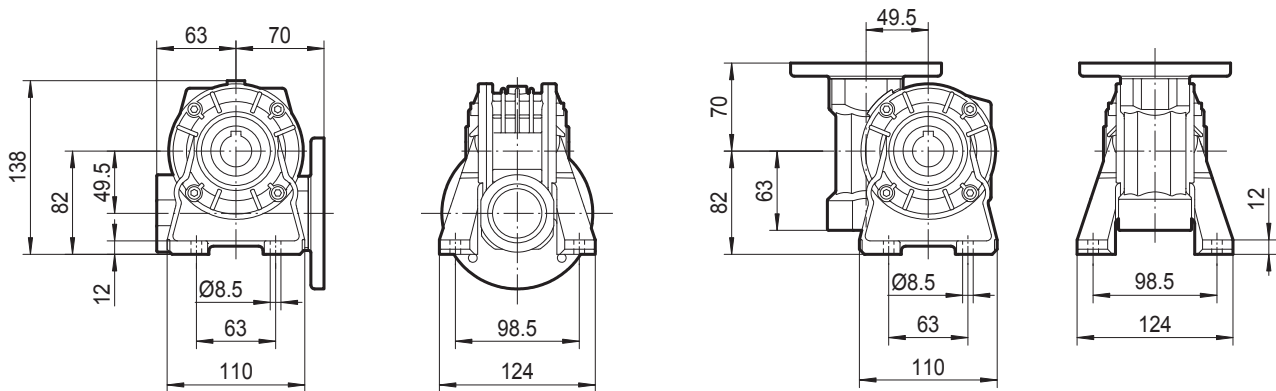

IEC	D _{E7}	b	t	P	M	N	R	S
63B5	11	4	12.8	140	115	95	10.5	9.5
63B14	11	4	12.8	90	75	60	7	6
71B5	14	5	16.3	160	130	110	10.5	9.5
71B14	14	5	16.3	105	85	70	10.5	6.5
80B5	19	6	21.8	200	165	130	10	11.5
80B14	19	6	21.8	120	100	80	10	7

MRDB49P..P(IEC)

Piedi / Input adapters

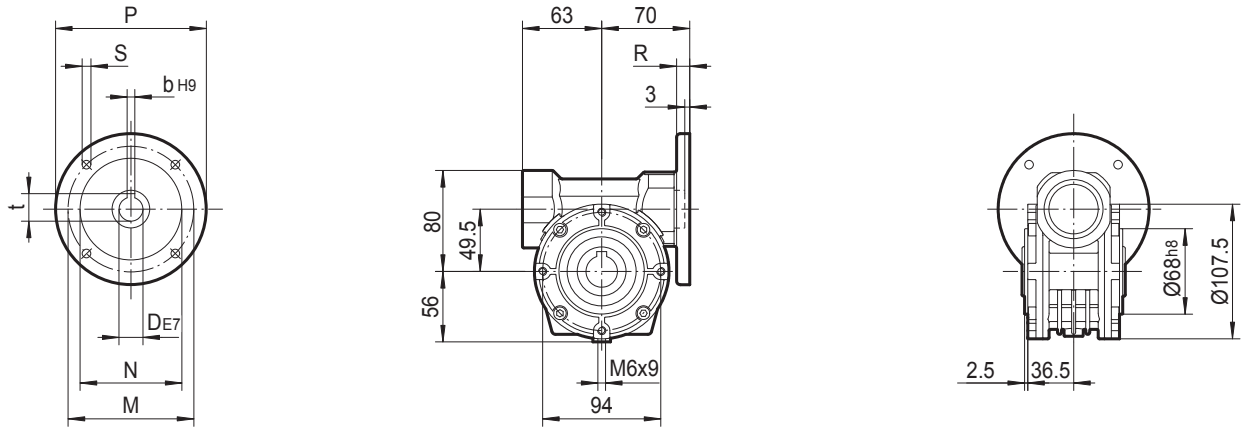

Dimensioni albero / Worm output shaft

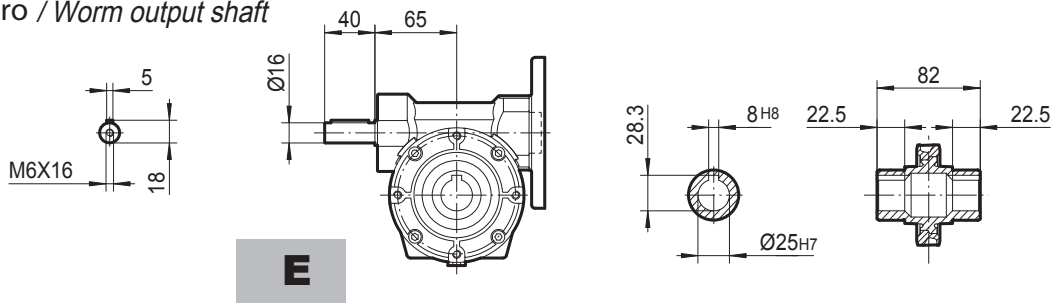

MRDB49F..

MRDB49FA..

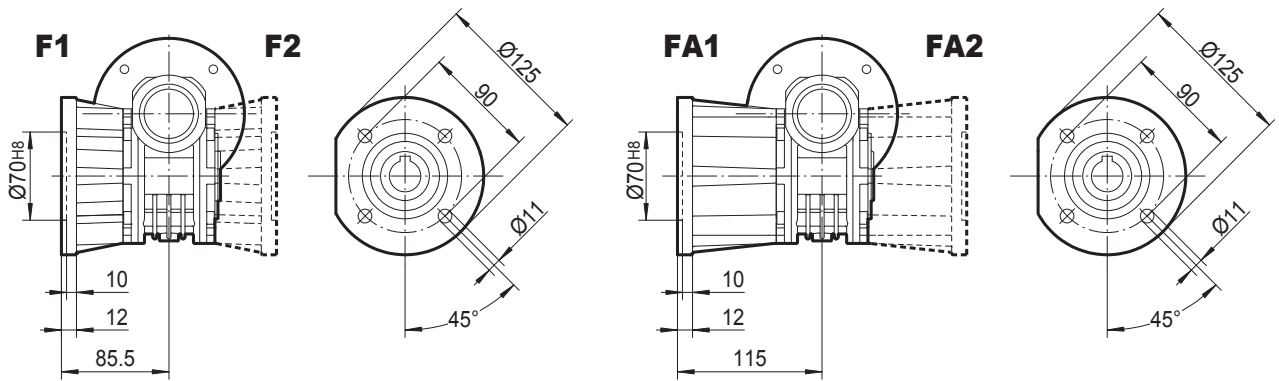

IEC	D E7	b	t	P	M	N	R	S
63B5	11	4	12.8	140	115	95	10.5	9.5
63B14	11	4	12.8	90	75	60	7	6
71B5	14	5	16.3	160	130	110	10.5	9.5
71B14	14	5	16.3	105	85	70	10.5	6.5
80B5	19	6	21.8	200	165	130	10	11.5
80B14	19	6	21.8	120	100	80	10	7

12.4.2 MRDB / MRDB., Dimensioni / Outline dimension

- Per le dimensioni delle flange in uscita andare a pag 13-18
- Per le dimensioni dell' albero vedere pag. 23
- Per le dimensioni dell' albero doppio vedere pag. 23

- For the dimensions of the tput flanges, please refer to pages 93-98.
- For the dimensions of the hollow shafts , please refer to pages 93-98.
- For the dimensions of the double extention warm shafts, please refer to page 103.

MRDB30/44..

A

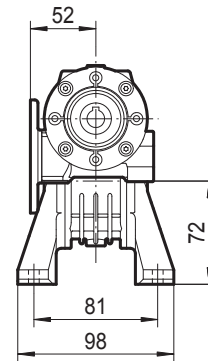
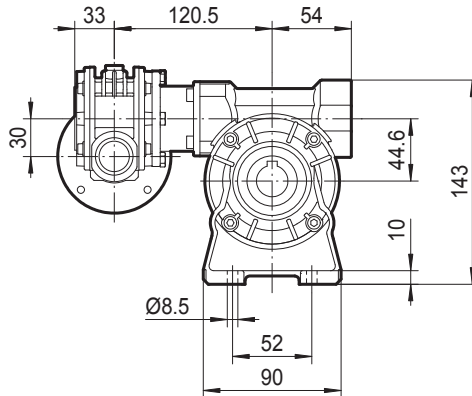

P

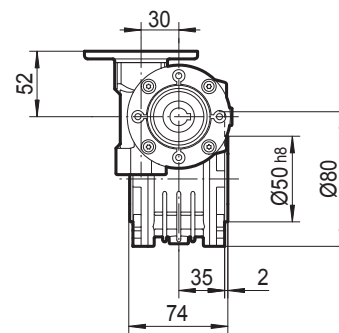
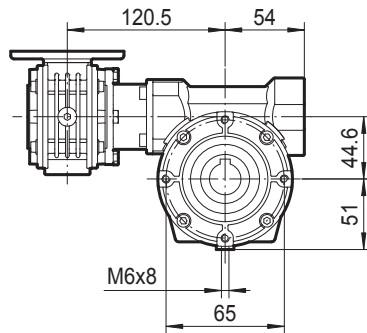

F_

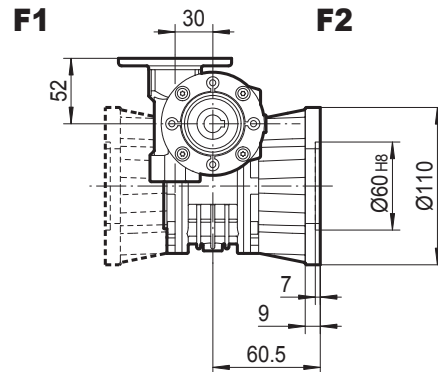
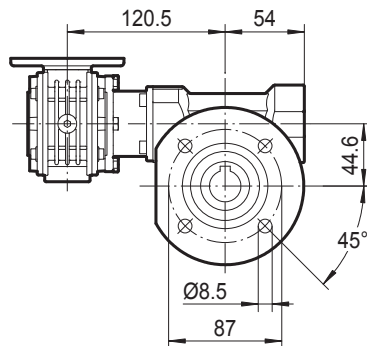

FA_

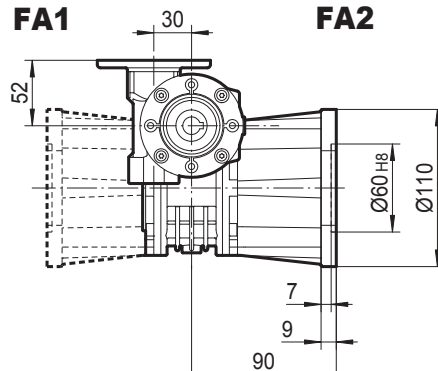
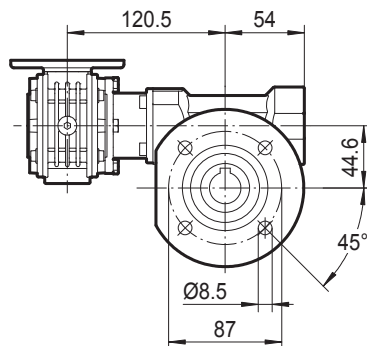

MRDB30/49..

A

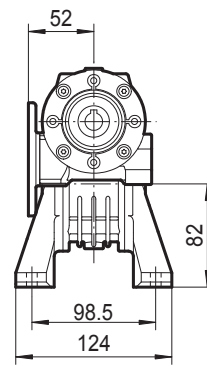
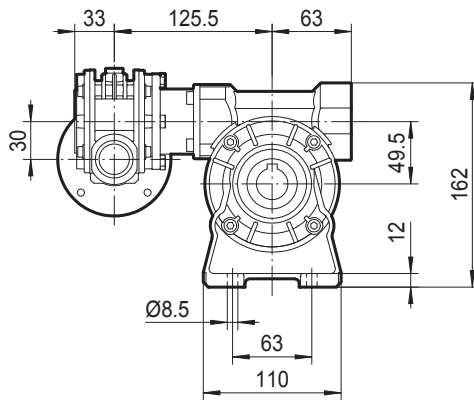

P

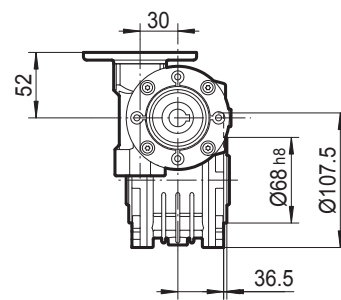
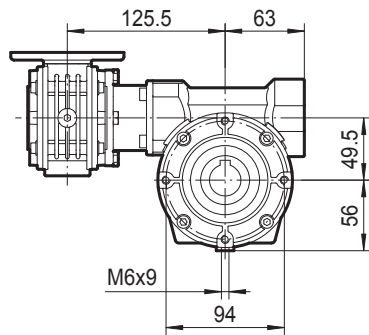

F_

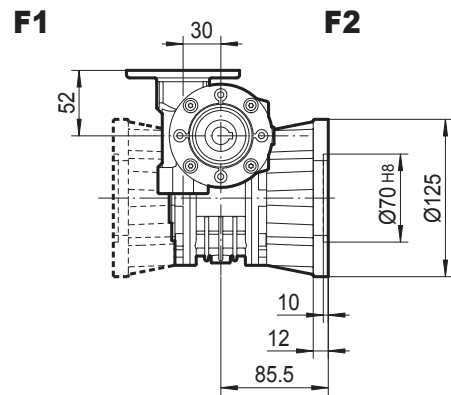
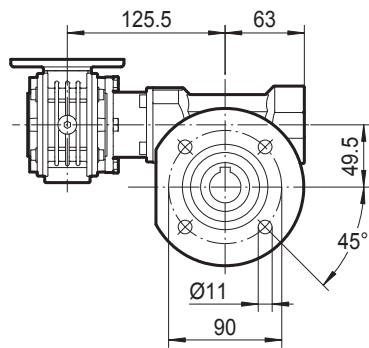

FA_

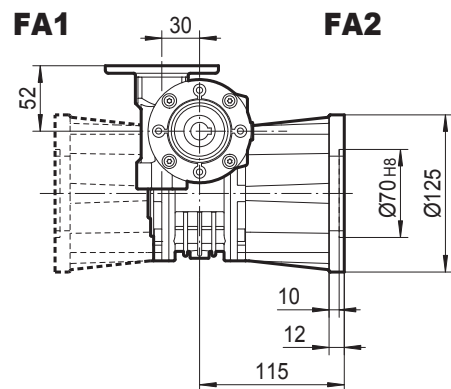
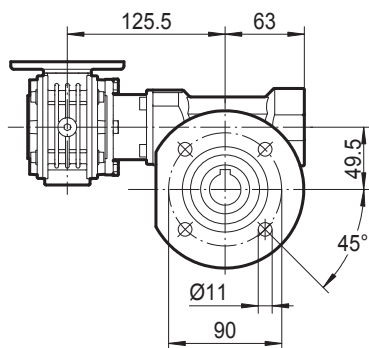

12.4.3 MRDB.. HS.. Dimensioni / Outline dimension

MRDB..HS..

MRDB_A..HS.

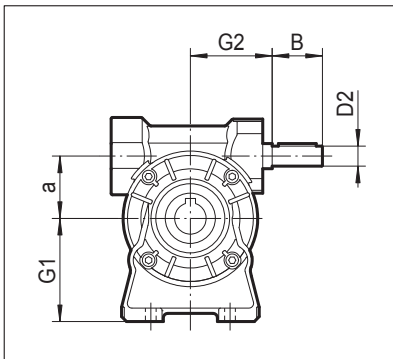

MRDB_V..HS.

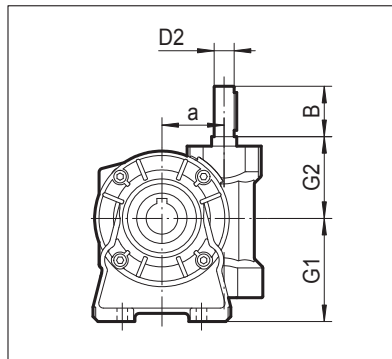

MRDB_N..HS.

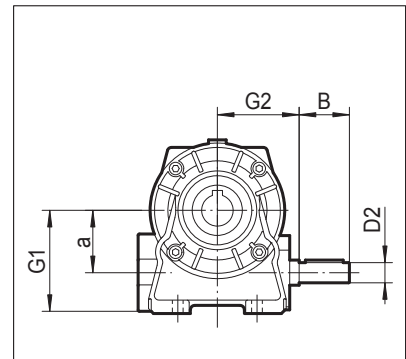

MRDB_P..HS.

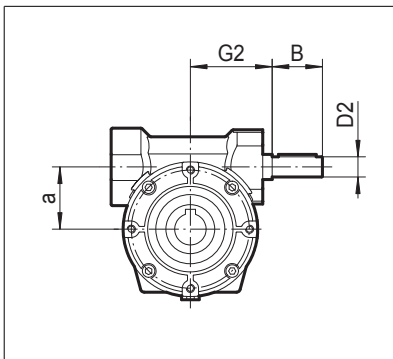

**MRDB_F..HS.
MRDB_FA..HS.**

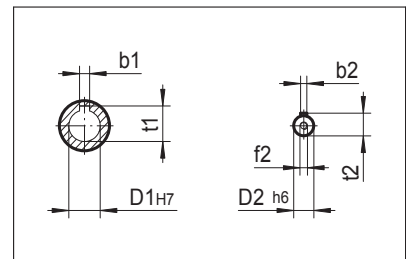
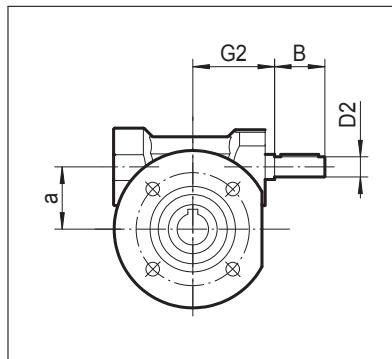

	a	D1 _{H7}	t1	b1	D2 _{h6}	t2	b2	B	G2	G1	f2
MRDB 30__HS	30	14	16.3	5	9	10.2	3	20	50	47	—
MRDB 44__HS	44.6	18	20.8	6	11	12.5	4	30	54	55	—
MRDB 49__HS	49.5	25	28.3	8	16	18	5	40	65	64.5	M6x16

12.4.4 **MRDB/MRDB.. HS..** Dimensioni / *Outline dimension*

MRDB/MRDB ..HS..

MRDB/MRDB_A..HS.

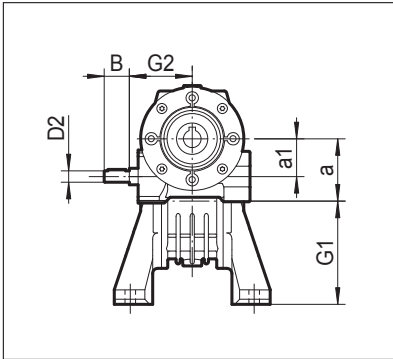

MRDB/MRDB_P..HS.

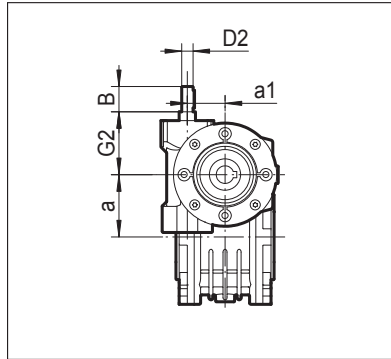

MRDB/MRDB_F..HS.

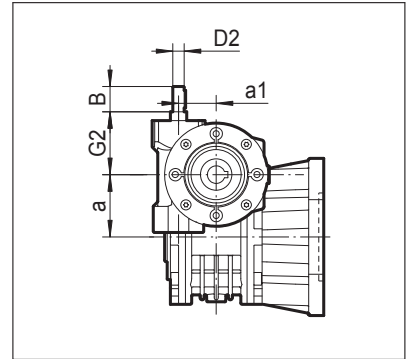

	a	a1	D1 _{H7}	t1	b1	D2 _{h6}
MRDB/MRDB 30/44_HS	44.6	30	18	20.8	6	9
MRDB/MRDV 30/49_HS	49.5	30	25	28.3	8	9
	t2	b2	B	G2	G1	f2
MRDB/MRDB 30/44_HS	10.2	3	20	50	72	—
MRDB/MRDB 30/49_HS	10.2	3	20	50	82	—

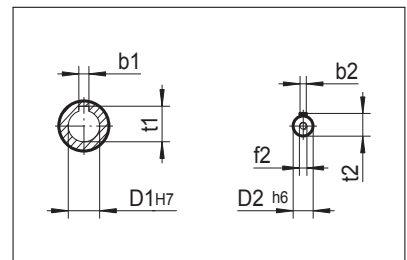

12.4.5 **MRDB/MRDB.. E(EO)..** Dimensioni / *Outline dimension*

I riduttori possono essere forniti su ordinazione con albero doppio in uscita

Worm gears can be optionally requested with extended wormshaft at NDE by specifying the option E or EO (for double worm combined units) at the time of order.

P(IEC)

HS

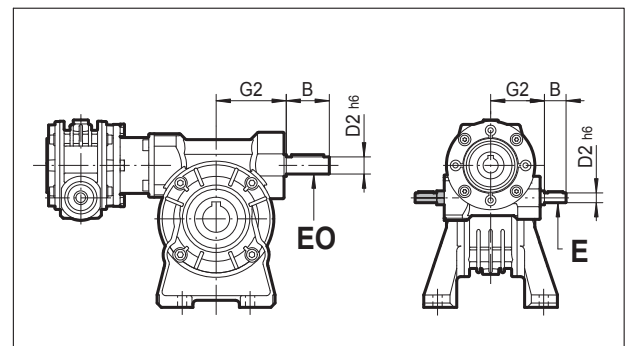
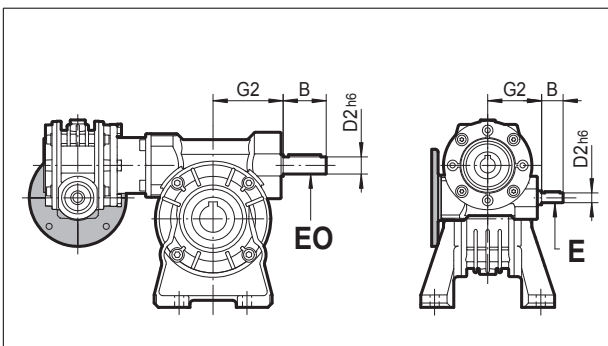

	D2 _{h6}	t2	b2	B	G2	f2
MRDB 30	9	10.2	3	20	50	-
MRDB 44	11	12.5	4	30	56	-
MRDB 49	16	18	5	40	65	M6

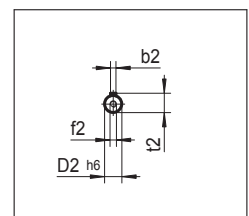

12.5 DIMENSIONI ACCESSORI / ACCESSORIES OUTLINE DIMENSION SHEET

12.5.1 Alberi in uscita / Output Shafts

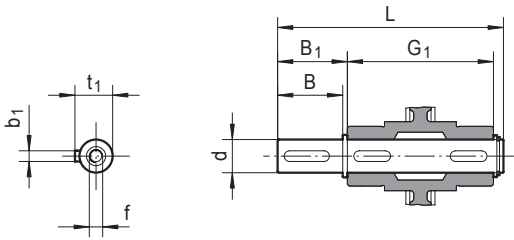

SS

	d _{h6}	B	B1	t1	L	f	G1	b1
MRDB 30	14	30	32.5	16	120	M5x13	55	5
MRDB 44	18	40	42.7	20.5	149.4	M6x16	64	6
MRDB 49	25	60	63.2	28	208.4	M8x19	82	8

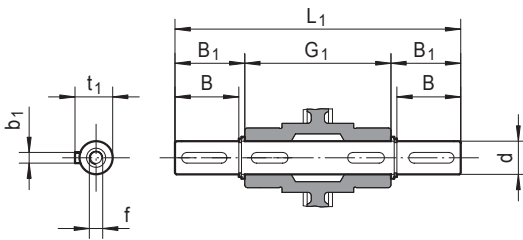

DS

	d _{h6}	B	B1	t1	L1	f	G1	b1
MRDB 30	14	30	32.5	16	120	M5x13	55	5
MRDB 44	18	40	42.7	20.5	149.4	M6x16	64	6
MRDB 49	25	60	63.2	28	208.4	M8x19	82	8

* Solo su richiesta
* Only on request

12.5.2 Braccio di reazione / Torque Arm

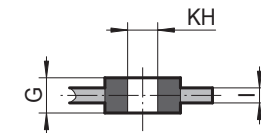
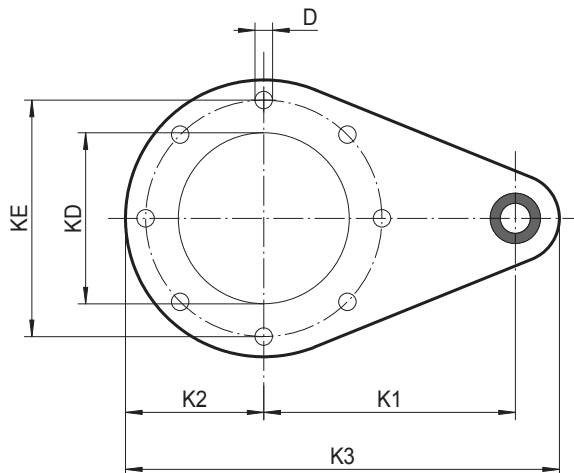

without vibration-dampening bushing

	K1	K2	K3	KD	KE	D	G	KH	I
MRDB 30	100	40	157.5	50	65	7	14	8	4
MRDB 44	100	40	157.5	50	65	7	14	8	4
MRDB 49	100	55	172.5	68	94	7	14	8	4



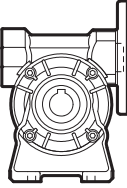
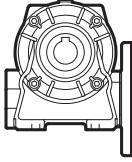
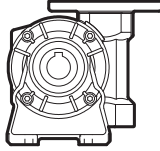
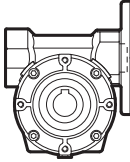
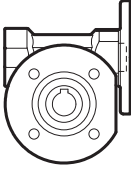
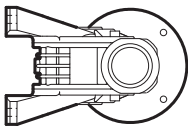
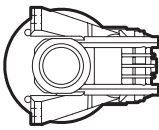
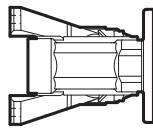
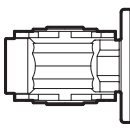
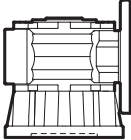
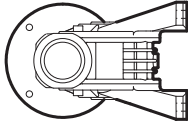
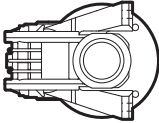
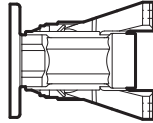
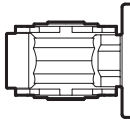
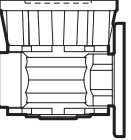
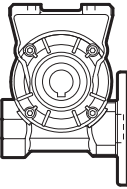
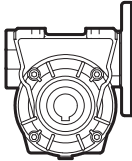
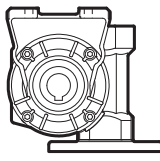
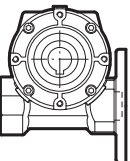
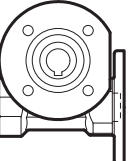
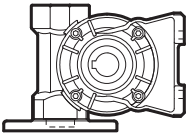
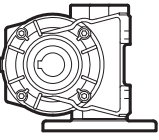
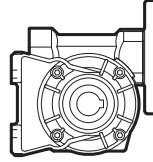
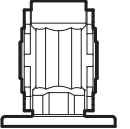
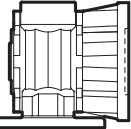
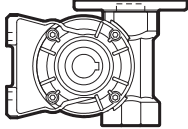
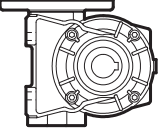
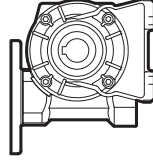
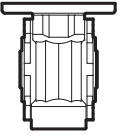
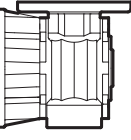

12.6 **MRDB..** SCHEMA POSIZIONI DI MONTAGGIO / **INSTALLATION POSITIONS DIAGRAM**

	MRDB..A	MRDB..N	MRDB..V	MRDB..P	MRDB..F
B3					
B6					
B7					
B8					
V5					
V6					

12.7 MRDB/MRDB.. COMBINATI / ARRANGEMENTS

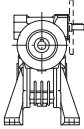
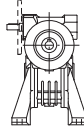
Per i riduttori combinati si prega attenersi alla sottoindicata tabella in fase d'ordine

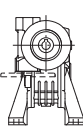
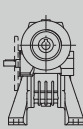
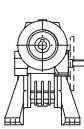
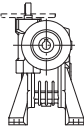
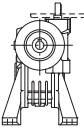
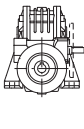
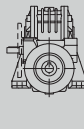
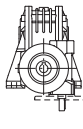
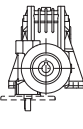
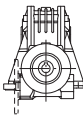
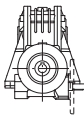
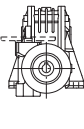
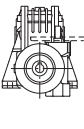
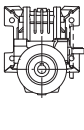
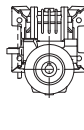
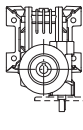
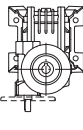
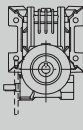
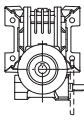
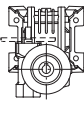
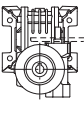
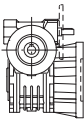
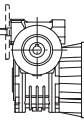
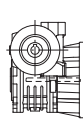
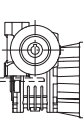
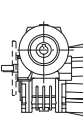
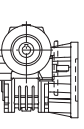
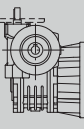
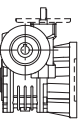
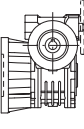
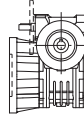
For combined worm gear units, unless otherwise specified at the time of ordering, the arrangements highlighted in grey in the diagrams below will be configured at the factory.

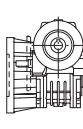
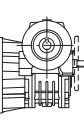
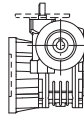
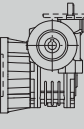
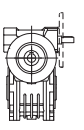
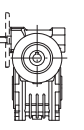
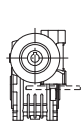
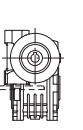
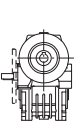
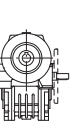
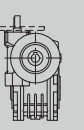
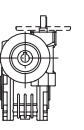
	MRDB1	MRDB2	MRDB3	MRDB4	MRDB5	MRDB6	MRDB7	MRDB8
A								
N								
V								
F1 FA1								
F2 FA2								
P								

MOUNTING POSITIONS

Per combinati con riduttore serie HS tutte le posizioni di montaggio sono disponibili. Per combinati tra riduttori PAM (IEC) alcune posizioni possono essere ottenute solo con flange IEC (B5 o B14)

For units with the **HS** input (free shaft), all the mounting options shown are available. For units with the **P (IEC)**, certain mounting options can be obtained only by using IEC flanges (**B5** or **B14**) of the same size or smaller than those shown in tables.

		MRDB1	MRDB2	MRDB3	MRDB4	MRDB5	MRDB6	MRDB7	MRDB8
MRDB/MRDB 30/44	N	56B14-63B14	56B14-63B14	56B14-63B14	56B14-63B14	56B14-63B14	56B14-63B14	56B14-63B14	56B14-63B14
	A								
	V								
	P/F								
MRDB/MRDB 30/49	N	56B14-63B14	56B14-63B14	56B14-63B14	56B14-63B14	56B14-63B14	56B14-63B14	56B14-63B14	56B14-63B14
	A								
	V								
	P								

12.7.2 Posizioni per albero in uscita / *Position diagram for single output shaft*

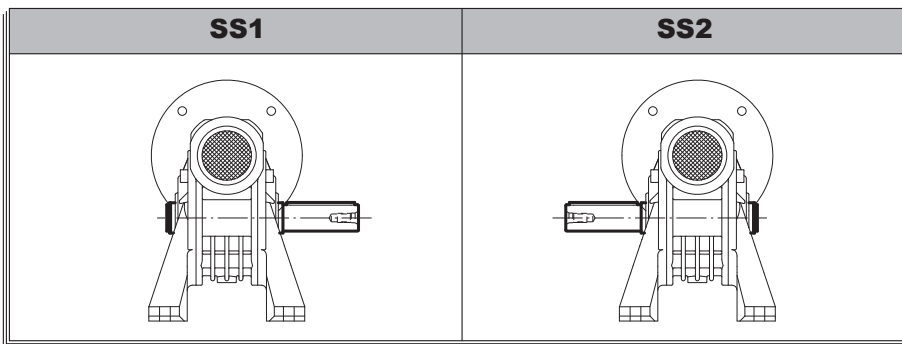

12.7.3 Posizioni morsettiera / *Position of terminal box*

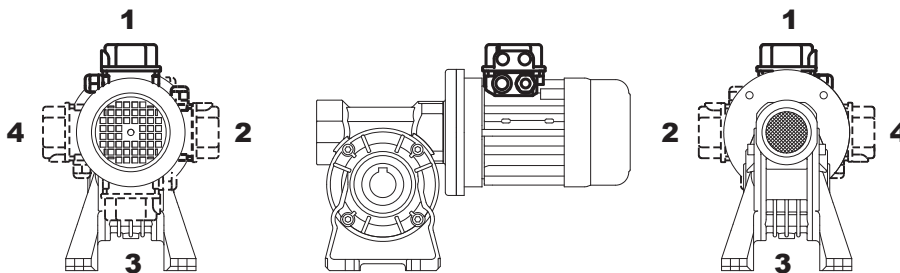

Specificare la posizione della morsettiera in fase d'ordine come da immagine.

In the case of specific requirements, when ordering, specify the position of the terminal box as shown in the diagram.

13. VARIATORI DI VELOCITA' / STEPLESS SPEED VARIATOR

13.1 Breve introduzioni ai variatori / Brief introduction to stepless speed variator

Il design dei variatori ha portato un avanzamento tecnologico sia a livello nazionale che internazionale. Le maggiori caratteristiche sono le seguenti:

1. Alta precisione nella regolazione della velocità: rotazioni da 0,5-1.
2. Vasta possibilità di variare la velocità. La velocità può essere variata da 1:1,4 a 1:7 liberamente.
3. Alta resistenza e lunga durata in servizio
4. Conveniente nel regolare la velocità
5. Continua in corsa, front-to-back in direzione di marcia, liscio nella guida, stabile in termini di prestazioni e basso nel rumore
6. Completo in tenuta e adatto a qualsiasi ambiente.
7. Compatto nella struttura e piccolo nel volume.
8. Fabbricato con alluminio pressofuso di alta qualità che dà un aspetto bello nell'apparenza e nella forma, leggero e senza problemi di ruggine.
9. Ottima capacità di adattarsi ad ogni applicazione. Si può combinare a qualsiasi riduttore riducendo o variando la velocità

I variatori UDL sono ampiamente utilizzati per la produzioni di cibo, ceramiche, imballaggi, farmaci, plastica e tutte quelle applicazioni dove si necessita la regolazione della velocità. Sono una valida soluzione per la produzione.

The design of UDL series stepless speed variator compromises the advanced technology both at home and abroad. The products include the following main characteristics:

1. High speed-regulating precision: up to 0.5-1 rotation.
2. Large speed –changing range: The speed ratio ranges from 1:1.4 to 1:7 freely.
3. High in strength and long in service life.
4. Convenient to regulate the speed.
5. Continuous in running, front-to-back in running direction, smooth in driving, stable in performance and low in noise.
6. Full in sealing and suitable for any environment.
7. Compact in structure and small in volume.
8. Made of high-quality aluminium alloy diecast into forming, good-looking in appearance, light in weight and it never gets rusty.
9. Good in adaptation: UDL series stepless speed variators can be combined with all kinds of speed reducers, as to achieve low stepless speed-changing.

UDL series stepless speed variators are widely used for foodstuffs, ceramics, packing, chemicals, pharmacy, plastics, paper-making, machine-tools, communications, and all kinds of automatic lines, pipelines and assembly lines which need speed-regulation, It is a good companion for your production.

13.2 Struttura / Structure

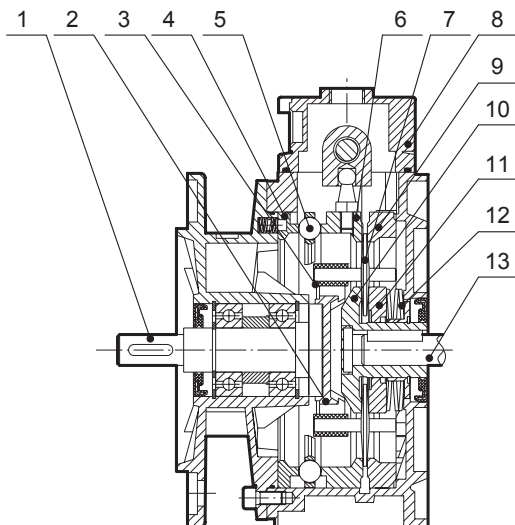

- | | |
|--|--------------------------------|
| 1. Albero in uscita | Output shaft |
| 2. Portasatelliti | Planet carrier |
| 3. Cuscinetti d'attrito - disco planetario | Friction bearing - planet disk |
| 4. Anello O-Ring | Cam ring |
| 5. Anello di aggiustaggio | Ball ring |
| 6. Disco planetario | Adjustable annulus ring |
| 7. Coperchio | Planet disk |
| 8. Anello di fissaggio | Control cover |
| 9. Pista esterna | Fixed annulus ring |
| 10. Pista centrale | Fixed sun race |
| 11. Pista centrale | Adjustable sun race |
| 12. Molla a tazza | Belleville spring |
| 13. Albero motore | Motor shaft |

13.3 Illustrazione modelli / *Model illuminate*

13.3.1 Variatori / *stepless speed variator*

VAR **L** **0.75** **B5** **B5**
 ① ② ③ ④ ⑤

No	Note	Comments
1	Codice variatore	Code of stepless speed variator
2	1). L: Carcassa alluminio 2). Nessuna indicazione = ghisa	1). L: Aluminium alloy casing 2). No mark means cast iron casing
3	Potenza motore	Motor power
4	1). B3: Versione a piedi 2). B5: Versione a flangia	1). B3: Foot-mounted model 2). B5: Flange-mounted model
5	Codice installazione	Code of installation positon

13.3.2 Combinazione con riduttori / *Combination of stepless speed variator and gear speed reducer*

VAR **0.75** **C** **B5** **B5**
 ① ② ③ ④ ⑤

No	Note	Comments
1	Codice variatore	Code of stepless speed variator with aluminium alloy casing
2	Potenza motore	Motor power
3	Codice riduttore	Code of gear reducer
4	1). B3: Versione a piedi 2). B5: Versione a flangia	1). B3: Foot-mounted model 2). B5: Flange-mounted model
5	Codice installazione	Code of installation positon

13.4 Immagine prodotto / **Product picture**



VAR..B3



VAR..B5

13.5 Prestazioni / **Performance parameter**

13.5.1 Prestazioni VAR / **Performance table for udl series speed variator**

($n_1 = 1400$ r/min)

	Model	i	n_2 [r/min]	M_2 [Nm]
0.18KW	VAR0.18	1.6 ~ 8.2	880 ~ 170	1.5 ~ 3
0.37KW	VAR0.37	1.4 ~ 7	1000 ~ 200	3 ~ 6
0.55KW	VAR0.55	1.4 ~ 7	1000 ~ 200	4 ~ 8
0.75KW	VAR0.75	1.4 ~ 7	1000 ~ 200	6 ~ 12
1.1KW	VAR1.1	1.4 ~ 7	1000 ~ 200	9 ~ 18
1.5KW	VAR1.5	1.4 ~ 7	1000 ~ 200	12 ~ 24
2.2KW	VAR2.2	1.4 ~ 7	1000 ~ 200	18 ~ 36
3.0KW	VAR3.0	1.4 ~ 7	1000 ~ 200	24 ~ 48
4.0KW	VAR4.0	1.4 ~ 7	1000 ~ 200	32 ~ 64
5.5KW	VAR5.5	1.4 ~ 7	1000 ~ 200	45 ~ 90
7.5KW	VAR7.5	1.4 ~ 7	1000 ~ 200	59 ~ 118

13.5.2 Prestazioni variatore con riduttore / **Performance table for stepless speed variator & gear speed reducer**

($n_1 = 1400$ r/min)

Model	i	n_2 [r/min]	M_2 [Nm]
VAR0.18-CB3	5	176 ~ 34	7 ~ 15
VAR0.37-CB3	5	200 ~ 40	15 ~ 30
VAR0.75-CB3	5	200 ~ 40	30 ~ 60

13.6 Dimensioni / Outline dimension sheet

13.6.1 B3 Modello / Model

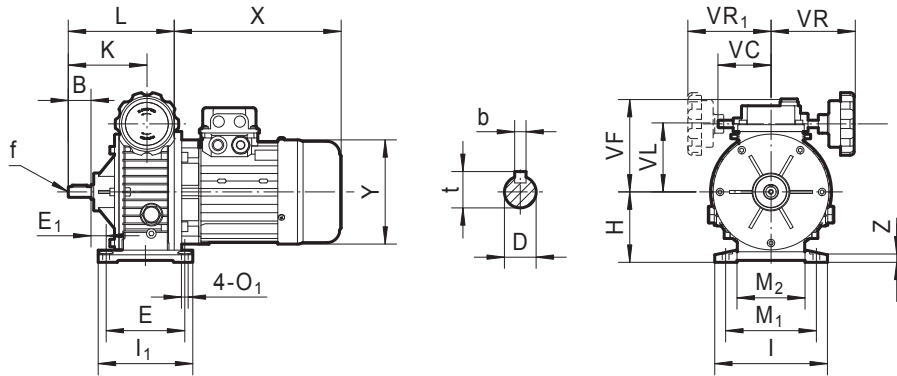

	B	D _{j6}	E	E ₁	H	I	I ₁	K	L	M ₁	M ₂	O ₁	VC	VF	VL	VR	VR ₁	VS	b	f	t	X	Y	Z
VAR.18B3	23	11	105	18	80	145	120	88	136	110	71	9	71	111	78	110	110	85	4	-	12.5	200	120	10
VAR0.37B3	30	14	104	20	93	149	125	104	140	120	96	9	71	123	90	110	110	85	5	M6	16	227	141	10
VAR0.75B3	40	19	125	26	113	190	150	126	179	160	135	11	79	140	107	120	120	110	6	M6	21.5	268	160	15
VAR1.1B3	40	24	105	35	100	207	130	136	187	160	115	13	-	124	102	150	-	110	8	M8	27	265	195	15
VAR1.5B3	50	24	115	54	123	241	150	165	238	190	143	13	-	144	122	150	-	110	8	M8	27	290	195	18
VAR2.2B3	60	28	230	25	150	300	270	191	268	245	190	14	-	188	150	150	-	110	8	M8	33	320	215	25
VAR3.0B3	60	28	230	25	150	300	270	191	268	245	190	14	-	188	150	150	-	110	8	M8	33	320	215	25
VAR4.0B3	60	28	230	25	150	300	270	191	268	245	190	14	-	188	150	150	-	110	8	M8	33	340	240	25
VAR5.5B3	70	35	250	33	200	365	290	201	319	315	245	18	-	-	192	192	-	110	10	M10	38	395	275	30
VAR7.5B3	70	35	250	33	200	365	290	201	319	315	245	18	-	-	192	192	-	110	10	M10	38	435	275	30

13.6.2 B5 Modello / Model

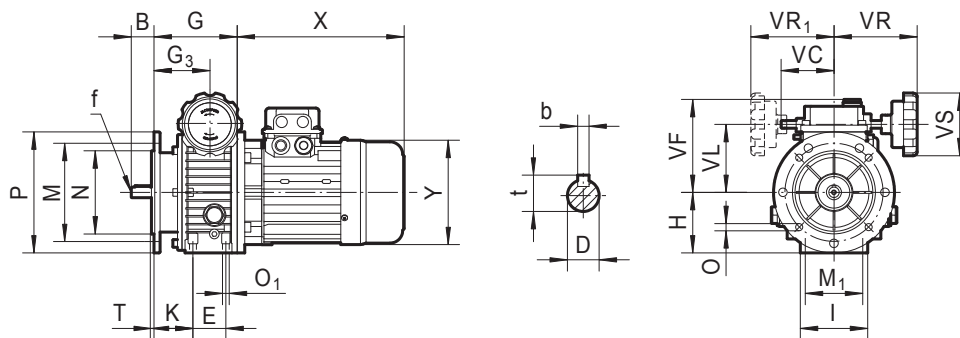

	B	D _{j6}	E	G	G ₃	H	I	M	M ₁	N	O	O ₁	P	T	K	VC	VF	VL	VR	VR ₁	VS	b	f	t	X	Y
VAR0.18B5	23	11	50	113	64.5	70	72	115	60	95	9	M6	140	3.5	46	71	111	78	110	110	85	4	-	13	200	120
VAR0.37B5	30	14	40	110	74	80	90	130	77	110	9	M8	160	3.5	53	71	123	90	100	110	85	5	M6	16	227	141
VAR0.75B5	40	19	58	139	85.5	100	98	165	84	130	11	M8	200	3.5	60	79	140	107	120	120	110	6	M6	22	268	160
VAR1.1B5	40	24	-	147	95	98	207	165	-	130	11	-	200	3.5	-	-	124	102	150	-	110	8	M8	27	265	195
VAR1.5B5	50	24	-	188	115	126	241	165	-	130	11	-	200	3.5	-	-	144	122	150	-	110	8	M8	27	290	195
VAR2.2B5	60	28	-	208	131	150	270	215	-	180	15	-	250	4	-	-	188	150	160	-	100	8	M8	33	320	215
VAR3.0B5	60	28	-	208	131	150	270	215	-	180	15	-	250	4	-	-	188	150	160	-	100	8	M8	33	320	215
VAR4.0B5	60	28	-	208	131	150	270	215	-	180	15	-	250	4	-	-	188	150	160	-	110	8	M8	33	340	240
VAR5.5B5	70	35	-	244	131	200	-	300	-	250	19	-	350	5	-	-	-	192	194	-	110	10	M10	38	395	275
VAR7.5B5	70	35	-	244	131	200	-	300	-	250	19	-	350	5	-	-	-	192	194	-	100	10	M10	38	435	275

13.6.3 Dimensioni e posizioni variatore versione a piedi con riduttori combinati

Combined outline & installation sizes for stepless speed variator & gear speed reducer with foot screws

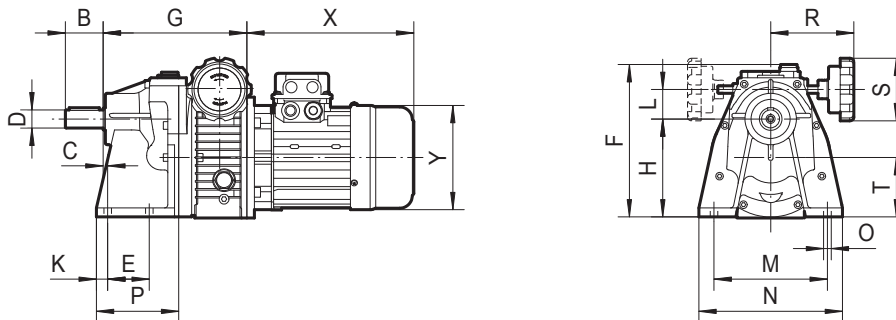

Modello Model	B	C	D	E	F	G	H	Y	L	M	N	O	P	R	S	T	X	K
VAR0.18-CB3	40	18	19	45	162	189	108	120	33	115	130	9	80	110	85	66	200	16
VAR0.37-CB3	50	6	24	70	187	190	130	141	39	150	190	10	110	100	85	79	227	15
VAR0.75-CB3	60	7	28	70	228	225	160	160	46	165	210	12	130	130	110	99	268	25

13.7 Posizione di montaggio / *Installation positions diagram*

B3	B6S	V1	V3	V5	V6
B8	B6D				
		Pos. of hand wheel		Pos. of terminal box	
		Standard pos. = 1			

- Per richieste speciali, indicare sull'ordine la posizione di montaggio della morsetteria. Senza specifiche il montaggio standard sarà quello da immagine
- Senza specifiche la posizione di montaggio standard è B3 o B5
- Per posizioni di montaggio non previste sullo schema si prega contattare il ns. ufficio tecnico.

- For special requirements, orders must specify the position of the terminal box with reference to the diagram. Unless otherwise specified the terminal box, the position of that will be mounted as shown in the diagram for the mounting position.
- Unless specified otherwise, the standard positions are B3 or B5.
- For positions not envisaged, it is necessary to call our Technical Service.

13.8 Manutenzione / Operation & maintenance

1. Le forme degli alberi sono tutte cilindriche. E' soggetto a GB1569-1190 Estensione cilindrica dell'albero. Le chiavette fanno riferimento alla GB1095-2003 Uniformità delle chiavette.
2. La linea dell'albero deve essere concentrica quando è connesso al motore. L'errore nell'installazione potrebbe causare problemi nell'accoppiamento.
3. Quando l'albero in uscita è installato nell'accoppiamento, deve essere pressato dentro il foro all'estremità dell'albero. Non martellare per pressare all'interno.
4. I variatori meccanici non sono utilizzati in applicazioni di sovraccarichi che potrebbero bloccare la funzionalità
5. La regolazione della velocità deve essere fatta in movimento. Non effettuare la manovra a macchina ferma.
6. Le due estremità della vite sono ben inserite. Si prega non toccarle.
7. Questi variatori non possono lavorare in ambienti al di sopra di 40°C, in particolare a non oltre i 40°C. Nel caso la temperatura si alzasse seguire quanto sotto indicato:

Se il motore è a 4Poli, la temperatura a pieno carico è di 40-50°C più alta rispetto alla normale temperatura di lavoro. Dopo 60-80 ore l'incremento della temperatura diminuirà gradualmente.

Da questo momento, la temperatura sarà di circa 20°C al di sopra di quello dell'ambiente. La temperatura si stabilizzerà.

La temperatura aumenta a causa della normale attività di lavoro del variatore. Questo incremento momentaneo non causa danni al variatore e alle sue parti.

8. L'olio lubrificante è utilizzato per il variatore. La marca è: Ub-3X. Verificare il livello dell'olio prima di utilizzare il variatore.
9. Il variatore è fornito già completo di olio. Quando inizia a lavorare oltre le 200 ore per la prima volta si consiglia sostituirlo. A seguito sostituire l'olio ogni 5000 ore di lavoro.
10. Il livello dell'olio nel variatore deve essere compreso nei 2/3 della scala. L'utilizzatore deve controllare periodicamente il livello dell'olio. E' severamente proibito mettere in funzione il variatore con quantità di olio inferiore a quella raccomandata. Il dado sulla scatola operativa è avvitato per evitare perdite di olio in movimento prima di lasciare la fabbrica. Deve essere svitato prima di mettere in funzione il variatore. E' severamente vietato utilizzare il variatore prima di svitare questo dado.

1. The shapes of shaft extension are all cylindrical. It is subject to GB1569-1990 Cylindrical shaft extension. The key joint refers to GB1095-2003 Ordinary flat key.

2. The shaft lines should be kept concentric when the coupling is connected with a motor. The installation error should be no more than the tolerance value of the coupling.

3. When the output shaft is installed with the coupling or belt wheel, they should be pressed into the screw hole on shaft end. Or assembled by heating. No hammering on it!

4. The mechanical stepless speed variator is not used in such an occasion where overload or running-blockage happen to occur.

5. Speed-regulation should be effected in running. Do not turn the hand wheel of speed-regulation when the machine stops!

6. The limit screws of speed-regulation on two ends under the operating box are well adjusted, Please don't touch them!

7. This set is not suited to work in the environment over 40°C, especially no more than 45°C when the temperature rises. In regard to its temperature rise, please read the explanation as follows:

If a 4-pole motor is used for the speed variator, the temperature under running-in (empty running) is 40-50°C higher than that of normal working environment. After running-in up to 60-80 hours, the temperature rise will go down gradually. From that time on, it is 20°C higher than of environment; and the temperature will keep on rising stably. The high temperature rise in running will affect normal permissive working condition, but it won't bring any bad effects to the service life of parts.

8. The liquid lubricating oil is used for the speed variator. Its trade mark is Ub-3x. Please check up the oil level before use.

9. The machine is filled with lubricating oil before leaving factory. When it starts to work up to 2000 hours for the first time, its lubricating oil should be replaced, changing the lubricating oil every 5000 hours later.

10. The lubricating oil level inside the speed variator should be kept at the height of two-third in the oil scale. Users should usually check the height of oil level. It is strictly prohibited to operate it when short of lubricating oil. The air screw nut on the operating box is screwed up for preventing from oil leakage in moving before leaving factory. It should be loosed when it starts to run. It is strictly forbidden to use it before loosening!

14. LUBRIFICANTE / LUBRICATION

In caso di ambienti con temperature non indicati in tabella, contattare il ns. ufficio tecnico

- In caso di temperature sotto i -30°C o sopra i 60°C è necessario utilizzare anelli di tenuta con materiale speciale.
- Per funzionalità in ambienti sotto gli 0°C è necessario considerare quanto segue:
 - Il motore deve essere predisposto per lavorare in speciali ambienti
 - La potenza del motore deve essere adeguata per supportare l'alta coppia in partenza richiesta
 - Nel caso di riduzione di velocità su variatori in ghisa fare attenzione all'impatto di carico in quanto sono più fragili a temperature al di sotto di -15°C
 - Durante i primi periodi di utilizzo, problemi di lubrificazione potrebbero essere dovuti all'alto livello di viscosità. Si consiglia mettere in funzione il variatore senza carichi per alcuni minuti.
 - L'olio deve essere sostituito approssimativamente ogni 10.000 ore. Questo periodo dipende dal tipo di servizio e dall'ambiente di lavoro
 - I riduttori serie MRDV 025-030-040-050-063-075-090-105, MRDB 30-49 sono forniti completi di lubrificante. Nel caso di posizioni di montaggio V5/V6 chiedere al ns. ufficio tecnico.
 - I riduttori serie MRDV 110-130-150 sono forniti completi olio mineral (SHELL TIVELA OIL 320)
 - I variatori sono forniti completi di olio minerale
 - Per i riduttori taglia 110-130-150 è necessario specificare la posizione di montaggio. Se non specificata verranno forniti in posizione B3
 - Le Precoppie serie PC sono fornite già lubrificate con olio sintetico tipo (SHELL TIVELA OIL 320) e possono essere montate in tutte le posizioni

In cases of ambient temperatures not envisaged in the table, call our Technical Service.

- In the case of temperatures under -30°C or over 60°C it is necessary to use oil seals with special material.
- For operating ranges with temperatures under 0°C it is necessary to consider the following:
 - The motors need to be suitable for operation at the envisaged ambient temperature.
 - The power of the electric motor needs to be adequate for exceeding the higher starting torques required.
 - In the case of reduction units with a cast-iron case, pay attention to impact loads since cast iron may have problems of fragility at temperatures under -15°C .
 - During the early stages of service, problems of lubrication may arise due to the high level of viscosity taken on by the oil and so it is wise to have a few minutes of rotation under no load.
 - The oil needs to be changed after approximately 10,000 hours. This period depends on the type of service and the environment where the reduction unit works.
 - The reduction units size MRDV 025-030-040-050-063-075-090-105, MRDB-44-49 are supplied complete with lubricant, and can therefore be mounted in any position envisaged in the catalogue. V5/V6 for which you should call our Technical Service to assess the conditions of use.
 - The reduction units size 110 and 130 are supplied complete with lubricant, mineral oil, (SHELL TEVELA OIL 320).
 - The variator speed are supplied complete with lubricant, mineral oil.
 - For sizes 110 and 130 it is necessary to specify the position, otherwise the reduction units are supplied with the quantity of oil relating to pos. B3.
 - PC is supplied complete with life-long lubricant, synthetic oil (SHELL TEVELA OIL 320), and can therefore be mounted in all the positions.

14.1 Tabella lubrificante / Lubricants oil chosen table

	°C -50 0 +50 +100	ISO	SHELL	AGIP	ESSO	MOBIL	CASTROL	BP	广研	
MRDV025~105 PC063~090 MRDB30~49	-25 +50	VG320	Tivela OIL S320	Telium VSF320	S220	Glygoyle 30	Alphasyn PG320	Energol SG-XP320		Synthetic oil
MRDV110~130	-5 +40	VG460	Omala OIL460	Blasia 460	Spartan EP460	Mobilgear 634	Alpha MAX 460	Energol GR-XP460	CKE460	Mineral oil
	-15 +25	VG220	Omala OIL220	Blasia 220	Spartan EP220	Mobilgear 630	Alpha MAX 220	Energol GR-XP220		
VAR	-25 +40	VG32	A.T.F.DXRON	A.T.F.DXRON	A.T.F.DXRON	A.T.F.220	TQ.DXRON II	Autran DX	Ub-3x	Mineral oil

14.2 Quantità lubrificante / Lubricant fill quantity

(L)

	B3	B6	B7	B8	V1、V5	V3、V6
MRDV 025				0.023		
MRDV 030				0.05		
MRDV 040				0.1		
MRDV 050				0.15		
MRDV 063				0.3		
MRDV 075				0.5		
MRDV 090				1		
MRDV 105				1.6		
MRDV 110	3	2.5	2.5	2.2	3	2.2
MRDV 130	4.5	3.5	3.5	3.3	4.5	3.3
PC063				0.05		
PC071				0.07		
PC080				0.15		
PC090				0.16		
VAR 0.18		0.13			0.2	
VAR 0.37		0.15			0.25	
VAR 0.55		0.33			0.45	
VAR 0.75		0.33			0.45	
VAR 1.1		0.8			1	
VAR1.5		0.8			1	
VAR 2.2		1.2			1.2	
VAR 3.0		1.2			1.2	
VAR4.0		1.2			1.2	
	B3	B6	B7	B8	V5	V6
MRDB30	0.045	0.045	0.045	0.045	0.045	0.045
MRDB44	0.075	0.075	0.075	0.075	0.075	0.075
MRDB49	0.12	0.12	0.12	0.12	0.12	0.12

La quantità di lubrificante dipende dal rapporto del riduttore e dalla posizione di montaggio.

The fill quantity in the table is referenced, the exact value relating to the ratio and mounting positions.

MRDV/MRDB/VAR

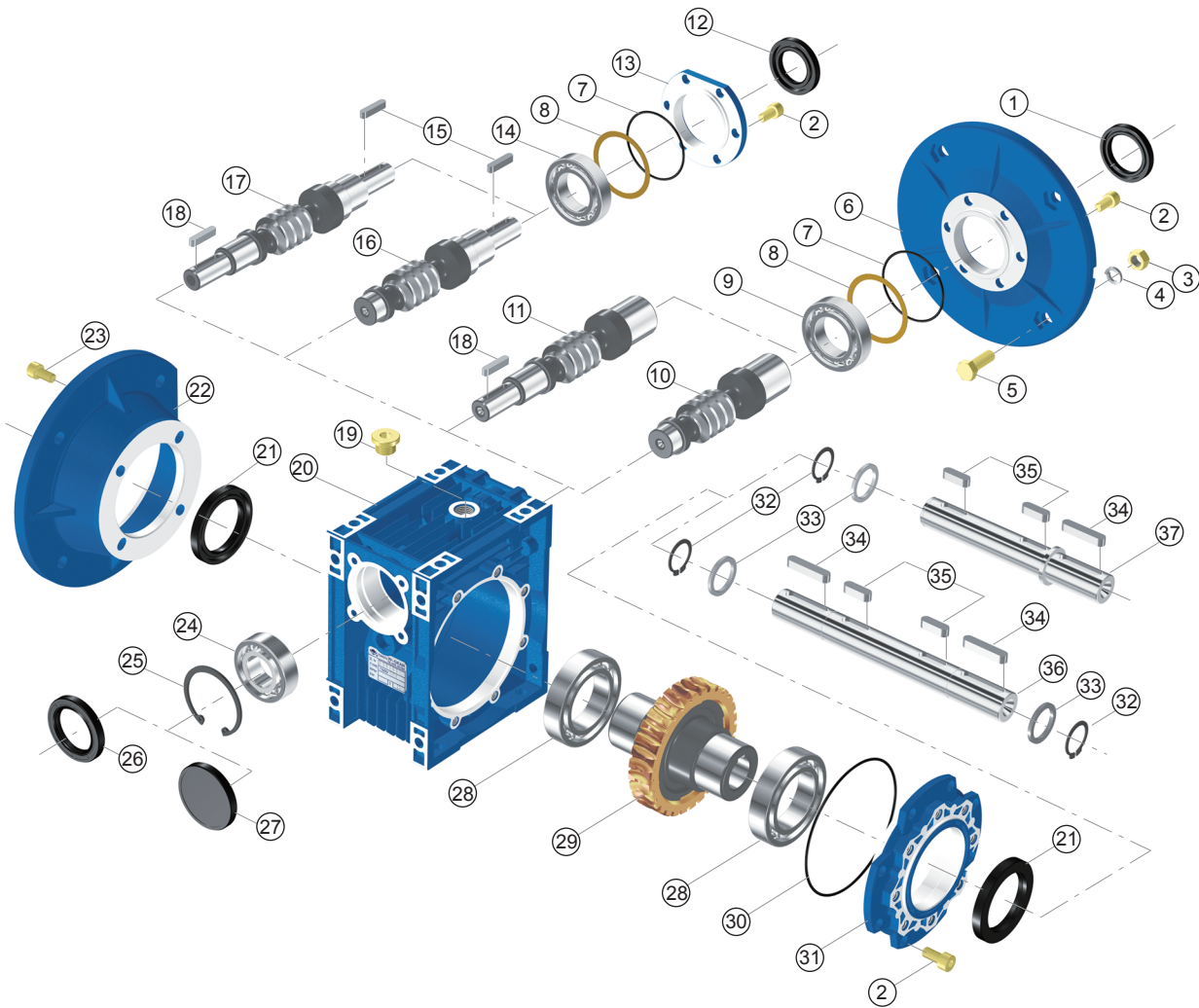

- | | | | |
|------------------------------------|-------------------------------|---------------------------------------|-------------------------|
| 1. Anello | 19. Tappo | 1. Oil seal | 19. Oil plug |
| 2. Vite | 20. Carcassa | 2. Inner hex screw | 20. Casing |
| 3. Dado | 21. Anello | 3. Nut | 21. Oil seal |
| 4. Rondella | 22. Flangia in uscita | 4. Spring washer | 22. Output flange |
| 5. Vite | 23. Vite | 5. Hex screw | 23. Inner hex screw |
| 6. Flangia in ingresso | 24. Cuscinetto | 6. Input flange | 24. Bearing |
| 7. O-Ring | 25. Seeger | 7. O-ring | 25. Hole-circlip |
| 8. Spessore | 26. Anello | 8. Adjust spacer | 26. Oil seal |
| 9. Cuscinetto | 27. Coperchio | 9. Bearing | 27. Cover |
| 10. Vite in ingresso | 28. Cuscinetto | 10. Hole input worm | 28. Bearing |
| 11. Vite in ingresso bisporgente | 29. Corona | 11. Hole input and shaft output worm | 29. Worm wheel |
| 12. Anello | 30. O-Ring | 12. Oil seal | 30. O-ring |
| 13. Coperchio | 31. Coperchio in uscita | 13. Input cover | 31. Output cover |
| 14. Cuscinetto | 32. Seeger | 14. Bearing | 32. Shaft-circlip |
| 15. Chiavetta | 33. Spessore | 15. Key | 33. Spacer |
| 16. Vite senza fine albero maschio | 34. Chiavetta | 16. Shaft input worm | 34. Key |
| 17. Vite senza fine doppia | 35. Chiavetta | 17. Shaft input and shaft output worm | 35. Key |
| 18. Chiavetta | 36. Albero in uscita doppio | 18. Key | 36. Double output shaft |
| | 37. Albero in uscita semplice | | 37. Single output shaft |

