

**- SERIE MRDV -**

**Riduttori a Vite Senza Fine -**

*MRDV Series Worm-Gear Speed Reducers*



**ELLE.GI SRL**

**Organi di Trasmissione**

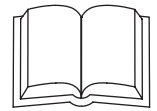

**PARAMETRI Mesh parameter**

	i	7.5	10	15	20	25	30	40	50	60	80	100
<b>MRDV025</b>	Z <sub>1</sub>	4	3	2	2	2	1	1	1	1		
	M <sub>n</sub>	1.3	1.3	1.3	0.995	0.8	1.3	0.995	0.8	0.67		
	γ	25°18'	19°31'	13°18'	11°02'	9°05'	6°44'	5°34'	4°34'	3°55'		
	η <sub>d</sub> (1400)	0.85	0.83	0.79	0.75	0.71	0.67	0.62	0.58	0.55		
	η <sub>s</sub>	0.71	0.68	0.61	0.56	0.5	0.46	0.41	0.36	0.34		
<b>MRDV030</b>	Z <sub>1</sub>	4	3	2	2	1	1	1	1	1	1	
	M <sub>n</sub>	1.44	1.44	1.44	1.1	1.7	1.44	1.1	0.89	0.74	0.56	
	γ	18°55'	14°25'	9°44'	7°50'	5°33'	4°54'	3°55'	3°17'	2°43'	2°07'	
	η <sub>d</sub> (1400)	0.85	0.82	0.77	0.73	0.68	0.65	0.59	0.55	0.51	0.44	
	η <sub>s</sub>	0.67	0.63	0.55	0.5	0.43	0.39	0.35	0.31	0.27	0.23	
<b>MRDV040</b>	Z <sub>1</sub>	4	3	2	2	2	1	1	1	1	1	1
	M <sub>n</sub>	2.05	2.05	2.05	1.56	1.27	2.05	1.56	1.27	1.06	0.8	0.65
	γ	23°54'	18°23'	12°30'	10°03'	8°45'	6°19'	5°04'	4°24'	3°42'	2°52'	2°29'
	η <sub>d</sub> (1400)	0.87	0.85	0.82	0.78	0.75	0.7	0.65	0.62	0.58	0.52	0.47
	η <sub>s</sub>	0.71	0.67	0.6	0.55	0.51	0.45	0.4	0.36	0.32	0.28	0.24
<b>MRDV050</b>	Z <sub>1</sub>	4	3	2	2	2	1	1	1	1	1	1
	M <sub>n</sub>	2.56	2.56	2.56	1.95	1.58	2.56	1.95	1.58	1.32	1	0.8
	γ	23°49'	18°19'	12°27'	10°03'	8°33'	6°18'	5°04'	4°18'	3°38'	2°52'	2°17'
	η <sub>d</sub> (1400)	0.88	0.86	0.82	0.79	0.76	0.72	0.67	0.63	0.59	0.53	0.49
	η <sub>s</sub>	0.7	0.66	0.59	0.55	0.51	0.44	0.39	0.35	0.32	0.27	0.23
<b>MRDV063</b>	Z <sub>1</sub>	4	3	2	2	2	1	1	1	1	1	1
	M <sub>n</sub>	3.25	3.25	3.25	2.48	2	3.25	2.48	2	1.68	1.27	1.02
	γ	24°31'	18°53'	12°51'	10°29'	8°45'	6°30'	5°17'	4°24'	3°49'	2°59'	2°26'
	η <sub>d</sub> (1400)	0.88	0.87	0.83	0.81	0.78	0.74	0.7	0.66	0.62	0.57	0.51
	η <sub>s</sub>	0.71	0.67	0.6	0.55	0.51	0.45	0.4	0.36	0.33	0.28	0.24
<b>MRDV075</b>	Z <sub>1</sub>	4	3	2	2	2	1	1	1	1	1	1
	M <sub>n</sub>	3.95	3.95	3.95	3	2.42	3.95	3	2.42	2.03	1.54	1.24
	γ	26°38'	20°37'	14°05'	11°19'	9°29'	7°09'	5°43'	4°46'	4°01'	3°17'	2°44'
	η <sub>d</sub> (1400)	0.89	0.88	0.85	0.82	0.8	0.76	0.72	0.69	0.65	0.6	0.55
	η <sub>s</sub>	0.71	0.68	0.61	0.57	0.53	0.46	0.42	0.38	0.35	0.29	0.26
<b>MRDV090</b>	Z <sub>1</sub>	4	3	2	2	2	1	1	1	1	1	1
	M <sub>n</sub>	4.84	4.84	4.84	3.69	2.98	4.84	3.69	2.98	2.5	1.89	1.52
	γ	29°05'	22°39'	15°33'	12°50'	10°53'	7°55'	6°30'	5°29'	4°46'	3°45'	3°06'
	η <sub>d</sub> (1400)	0.9	0.89	0.86	0.84	0.82	0.78	0.75	0.72	0.69	0.63	0.59
	η <sub>s</sub>	0.73	0.7	0.64	0.6	0.56	0.49	0.45	0.41	0.38	0.32	0.28
<b>MRDV110</b>	Z <sub>1</sub>	4	3	2	2	2	1	1	1	1	1	1
	M <sub>n</sub>	5,875	5,875	5,875	4.62	3.73	5,875	4.62	3.73	3.13	2.37	1.91
	γ	28°15'	21°57'	15°02'	14°42'	12°33'	7°39'	7°29'	6°21'	5°33'	4°27'	3°46'
	η <sub>d</sub> (1400)	0.9	0.89	0.86	0.85	0.84	0.79	0.78	0.75	0.72	0.67	0.63
	η <sub>s</sub>	0.72	0.69	0.63	0.62	0.59	0.48	0.48	0.44	0.41	0.36	0.32
<b>MRDV130</b>	Z <sub>1</sub>	4	3	2	2	2	1	1	1	1	1	1
	M <sub>n</sub>	6.97	6.97	6.97	5.4	4.37	6.97	5.4	4.37	3.67	2.77	2.23
	γ	28°43'	22°20'	15°19'	13°47'	11°54'	7°48'	7°00'	6°01'	5°16'	4°07'	3°27'
	η <sub>d</sub> (1400)	0.91	0.89	0.87	0.86	0.84	0.8	0.78	0.75	0.72	0.68	0.64
	η <sub>s</sub>	0.72	0.69	0.63	0.61	0.58	0.49	0.46	0.43	0.39	0.34	0.3

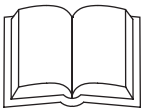

## DATI TECNICI - TECHNICAL DATA

### PREDISPOSIZIONI - Predisposition

(\*) Per un ingresso con motore speciale contattare il nostro ufficio tecnico

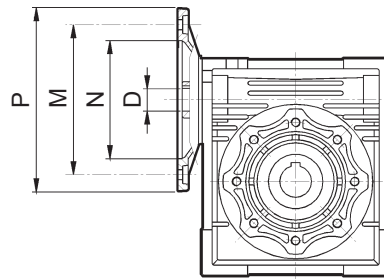

(\*) If you want special key, please call our Technical Service

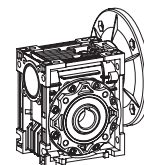

MRDV	PAM IEC	N	M	P	D											
					7.5	10	15	20	25	30	40	50	60	80	100	
025	56B14	50	65	80	9	9	9	9		9	9	9	9			
030	63B5	95	115	140	11	11	11	11	11	11	11	11				
	63B14	60	75	90												
	56B5	80	100	120	9	9	9	9	9	9	9	9	9	9		
	56B14	50	65	80												
040	71B5	110	130	160	14	14	14	14	14	14	14					
	71B14	70	85	105												
	63B5	95	115	140	11	11	11	11	11	11	11	11	11	11	11	11
	63B14	60	75	90												
	56B5	80	100	120								9	9	9	9	
050	80B5	130	165	200	19	19	19	19	19	19						
	80B14	80	100	120												
	71B5	110	130	160	14	14	14	14	14	14	14	14	14	14		
	71B14	70	85	105												
	63B5	95	115	140							11	11	11	11	11	
063	90B5	130	165	200	24	24	24	24	24	24						
	90B14	95	115	140												
	80B5	130	165	200	19	19	19	19	19	19	19	19	19			
	80B14	80	100	120												
	71B5	110	130	160												
	71B14	70	85	105							14	14	14	14	14	
075	100/112B5	180	215	250	28	28	28									
	100/112B14	110	130	160												
	90B5	130	165	200	24	24	24	24	24	24						
	90B14	95	115	140												
	80B5	130	165	200				19	19	19	19	19	19	19	19	19
	80B14	80	100	120												
	71B5	110	130	160								14	14	14	14	14
090	100/112B5	180	215	250	28	28	28	28	28	28						
	100/112B14	110	130	160												
	90B5	130	165	200	24	24	24	24	24	24	24	24	24			
	90B14	95	115	140												
	80B5	130	165	200							19	19	19	19	19	19
	80B14	80	100	120												
110	132B5	230	265	300	38*	38*	38*	38*								
	100/112B5	180	215	250	28	28	28	28	28	28	28	28	28			
	90B5	130	165	200					24	24	24	24	24	24	24	24
	80B5	130	165	200											19	19
130	132B5	230	265	300	38*	38*	38*	38*	38*	38*	38*					
	100/112B5	180	215	250					28	28	28	28	28	28	28	28
	90B5	130	165	200											24	24

# PRESTAZIONI - PERFORMANCE PARAMETER

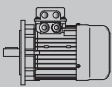



$P_1$ [kW]	$n_2$ [min <sup>-1</sup> ]	$M_2$ [Nm]	$i$	$Fr_2$ [N]	$f_s$			
<b>0.25</b>	70	27	20	2503	2.7	<b>MRDV050</b>	<b>7114</b>	61
	56	32	25	2696	2.2			
	46.7	37	30	2865	2.3			
	35	46	40	3153	1.7			
	28	54	50	3397	1.4			
	23.3	60	60	3610	1.1			
	17.5	72	80	3973	0.9			
	45	40	20	2900	1.9	<b>MRDV050</b>	<b>7126</b>	61
	36	48	25	3124	1.5			
	30	54	30	3320	1.7			
	22.5	67	40	3654	1.2			
	18	78	50	3936	1			
	15	88	60	4183	0.8			
	18.7	88	75	3889	1	<b>PC071+MRDV050</b>	<b>7114</b>	68
	15.6	98	90	4132	1.1			
	11.7	121	120	4548	0.8			
	28	56	50	4440	2.4	<b>MRDV063</b>	<b>7114</b>	62
	23.3	63	60	4719	2			
	17.5	78	80	5193	1.6			
	14	87	100	5595	1.4			
	18	81	50	5145	1.8	<b>MRDV063</b>	<b>7126</b>	62
	15	92	60	5467	1.5			
	11.3	110	80	6018	1.2			
	9	125	100	6270	1			
	18.7	91	75	5083	1.8	<b>PC071+MRDV063</b>	<b>7114</b>	68
	15.6	100	90	5401	2			
	11.7	125	120	5945	1.5			
	9.3	143	150	6270	1.2			
	7.8	163	180	6270	1			
	5.8	192	240	6270	0.7			
	4.7	215	300	6270	0.6			
	12	135	75	5889	1.6			
	10	148	90	6259	1.8	<b>PC071+MRDV063</b>	<b>7126</b>	68
	7.5	181	120	6270	1.3			
	6	211	150	6270	1			
	7	159	400	6270	1.4			
	5.6	185	500	6270	1.2			
	17.5	82	80	6130	2.3	<b>MRDV075</b>	<b>7114</b>	63
	14	94	100	6603	1.9			

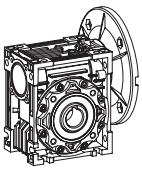



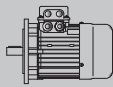

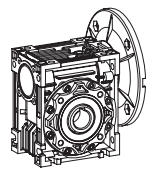

## PRESTAZIONI - PERFORMANCE PARAMETER

$P_1$ [kW]	$n_2$ [min <sup>-1</sup> ]	$M_2$ [Nm]	$i$	$Fr_2$ [N]	$fs$			
<b>0.25</b>	11.3	117	80	7103	1.7	<b>MRDV075</b>	<b>7126</b>	63
	9	133	100	7380	1.4			
	9.3	151	150	7380	1.7	<b>PC071+MRDV075</b>	<b>7114</b>	69
	7.8	172	180	7380	1.4			
	5.8	201	240	7380	1.1			
	4.7	230	300	7380	0.9			
	12	139	75	6952	2.4	<b>PC071+MRDV075</b>	<b>7126</b>	69
	10	155	90	7380	2.5			
	7.5	191	120	7380	1.9			
	6	219	150	7380	1.5			
	5	248	180	7380	1.2			
	3.5	336	400	7380	1.1			
	2.8	384	500	7380	0.8			
	5	263	180	8180	1.9	<b>PC071+MRDV090</b>	<b>7126</b>	69
	3.8	318	240	8180	1.4			
	3	358	300	8180	1.1			
	2.3	512	600	8180	1.2	<b>MRDV040+090</b>	<b>7114</b>	73
	1.9	598	750	8180	0.9			
	1.6	667	900	8180	0.8			
	1.2	943	1200	10320	1.3			
0.93	1064	1500	10320	1.2				
0.78	1195	1800	10320	1.1				
0.6	1624	2400	13500	1	<b>MRDV063+130</b>	<b>7114</b>	74	
0.47	1935	3000	13500	0.8				
0.35	2046	4000	13500	0.6				
0.28	2430	5000	13500	0.5				
<b>0.37</b>	373.3	8.4	7.5	1044	3.3	<b>MRDV040</b>	<b>7112</b>	60
	280	11	10	1149	2.6			
	186.7	16	15	1315	1.9			
	140	21	20	1447	1.4	<b>MRDV040</b>	<b>7112</b>	60
	112	25	25	1559	1.1			
	186.7	16	7.5	1315	2.4	<b>MRDV040</b>	<b>7124</b>	60
	140	21	10	1447	1.9			
	93.3	31	15	1657	1.3			
	70	39	20	1824	1			
	56	47	25	1964	0.8			
	46.7	53	30	2087	0.8			

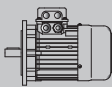

# PRESTAZIONI - PERFORMANCE PARAMETER

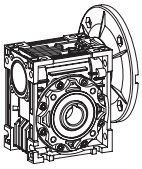

$P_1$ [kW]	$n_2$ [min <sup>-1</sup> ]	$M_2$ [Nm]	$i$	$Fr_2$ [N]	$fs$			
<b>0.37</b>	112	25	25	2140	2	<b>MRDV050</b>	<b>7112</b>	61
	93.3	29	30	2274	2.2			
	70	37	40	2503	1.6			
	56	44	50	2696	1.2			
	46.7	50	60	2865	1	<b>MRDV050</b>	<b>7112</b>	61
	35	62	80	3153	0.7			
	140	22	10	1987	3.3	<b>MRDV050</b>	<b>7124</b>	61
	93.3	31	15	2274	2.4			
	70	40	20	2503	1.8			
	56	48	25	2696	1.5			
	46.7	55	30	2865	1.5			
	35	68	40	3153	1.1			
	28	80	50	3397	0.9	<b>MRDV050</b>	<b>7124</b>	61
	23.3	89	60	3610	0.8			
	120	25	7.5	2091	3.3	<b>MRDV050</b>	<b>8016</b>	61
	90	33	10	2302	2.5			
	60	47	15	2635	1.8			
	45	60	20	2900	1.3			
	36	72	25	3124	1			
	30	80	30	3320	1.1			
35	71	40	4122	2.1	<b>MRDV063</b>	<b>7124</b>	62	
28	83	50	4440	1.6				
23.3	94	60	4719	1.4				
17.5	115	80	5193	1.1				
14	129	100	5595	0.9				
45	60	20	3791	2.4	<b>MRDV063</b>	<b>8016</b>	62	
36	74	25	4084	1.9				
30	82	30	4339	2.1				
22.5	102	40	4776	1.6				
18	120	50	5145	1.2				
15	137	60	5467	1				
18.7	134	75	5083	1.2	<b>PC071+MRDV063</b>	<b>7124</b>	68	
15.6	148	90	5401	1.4				
11.7	185	120	5945	1				
9.3	212	150	6270	0.8				
9.3	181	300	6270	1.3	<b>MRDV030+063</b>	<b>7112</b>	72	
7	236	400	6270	1				
23.3	98	60	5569	2	<b>MRDV075</b>	<b>7124</b>	63	
17.5	121	80	6130	1.6				
14	139	100	6603	1.3				



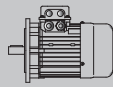

## PRESTAZIONI - PERFORMANCE PARAMETER

$P_1$ [kW]	$n_2$ [min <sup>-1</sup> ]	$M_2$ [Nm]	$i$	$Fr_2$ [N]	$fs$			
<b>0.37</b>	18	126	50	6073	1.8	<b>MRDV075</b>	<b>8016</b>	63
	15	144	60	6453	1.5			
	11.3	173	80	7103	1.2			
	9	196	100	7380	1			
	18.7	138	75	6000	1.8	<b>PC071+MRDV075</b>	<b>7124</b>	69
	15.6	154	90	6375	1.9			
	11.7	191	120	7017	1.5			
	9.3	223	150	7380	1.1			
	7.8	254	180	7380	0.9			
	12	206	75	6952	1.6	<b>PC080+MRDV075</b>	<b>8016</b>	69
	10	230	90	7380	1.7			
	7.5	283	120	7380	1.3			
	6	324	150	7380	1			
	4.7	405	300	7380	1	<b>MRDV040+075</b>	<b>7124</b>	73
	3.5	498	400	7380	0.7			
	11.3	185	80	7859	1.7	<b>MRDV090</b>	<b>8016</b>	64
	9	212	100	8180	1.3			
	7.8	268	180	8180	1.5	<b>PC071+MRDV090</b>	<b>7124</b>	69
	5.8	321	240	8180	1.1			
	4.7	371	300	8180	0.9			
6	347	150	8180	1.6	<b>PC080+MRDV090</b>	<b>8016</b>	70	
5	389	180	8180	1.3				
3.8	471	240	8180	1				
4.7	402	300	8180	1.5	<b>MRDV040+090</b>	<b>7124</b>	73	
3.5	523	400	8180	1.2				
2.8	611	500	8180	0.9				
2.3	757	600	8180	0.8				
3.8	509	240	10320	1.6	<b>PC080+MRDV110</b>	<b>8016</b>	70	
3	577	300	10320	1.3				
1.9	950	750	10320	1.3	<b>MRDV050+110</b>	<b>7124</b>	73	
1.6	1079	900	10320	1.2				
1.2	1396	1200	10320	0.8				
0.9	1674	1500	13500	1.1	<b>MRDV063+130</b>	<b>7124</b>	74	
0.78	1887	1800	13500	0.9				
<b>0.55</b>	373.3	13	7.5	1044	2.2	<b>MRDV040</b>	<b>7122</b>	60
	280	17	10	1149	1.8			
	186.7	24	15	1315	1.3			
	140	31	20	1447	0.9			
	112	37	25	1559	0.8			

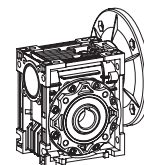

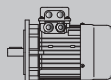
# PRESTAZIONI - PERFORMANCE PARAMETER

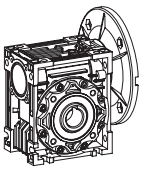

$P_1$ [kW]	$n_2$ [min <sup>-1</sup> ]	$M_2$ [Nm]	$i$	$Fr_2$ [N]	$f_s$			
<b>0.55</b>	140	31	20	1987	1.7	<b>MRDV050</b>	<b>7122</b>	61
	112	38	25	2140	1.4			
	93.3	43	30	2274	1.5			
	70	55	40	2503	1.1			
	56	65	50	2696	0.8			
	46.7	74	60	2865	0.7			
186.7	25	7.5	1805	2.9	<b>MRDV050</b>	<b>8014</b>	61	
140	32	10	1987	2.2	<b>MRDV050</b>	<b>8014</b>	61	
93.3	46	15	2274	1.6				
70	59	20	2503	1.2				
56	71	25	2696	1				
46.7	81	30	2865	1				
120	38	7.5	2091	2.2				<b>MRDV050</b>
90	49	10	2302	1.7				
60	69	15	2635	1.2				
45	89	20	2900	0.9				
70	56	40	3272	1.9	<b>MRDV063</b>	<b>7122</b>	62	
56	67	50	3524	1.5				
46.7	77	60	3745	1.2				
35	95	80	4122	0.9				
28	109	100	4440	0.7				
70	61	20	3272	2.2				<b>MRDV063</b>
56	73	25	3524	1.8				
46.7	83	30	3745	1.9				
35	105	40	4122	1.4				
28	124	50	4440	1.1				
23.3	140	60	4719	0.9				
60	71	15	3444	2.2	<b>MRDV063</b>	<b>8026</b>	62	
45	90	20	3791	1.6				
36	109	25	4084	1.3				
30	123	30	4339	1.4				
22.5	152	40	4776	1.1				
35	99	80	4865	1.3	<b>MRDV075</b>	<b>7122</b>	63	
28	114	100	5241	1				
35	108	40	4865	2	<b>MRDV075</b>	<b>8014</b>	63	
28	129	50	5241	1.6				
23.3	146	60	5569	1.4				
17.5	180	80	6130	1.1				
14	206	100	6603	0.9				



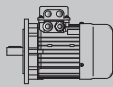



## PRESTAZIONI - PERFORMANCE PARAMETER

$P_1$ [kW]	$n_2$ [min <sup>-1</sup> ]	$M_2$ [Nm]	$i$	$F_{r2}$ [N]	$f_s$			
<b>0.55</b>	30	128	30	5122	2	<b>MRDV075</b>	<b>8026</b>	65
	22.5	159	40	5637	1.5			
	18	187	50	6073	1.2			
	15	214	60	6453	1			
	18.7	205	75	6000	1.2	<b>PC080+MRDV075</b>	<b>8014</b>	69
	15.6	230	90	6375	1.3			
	11.7	284	120	7017	1			
	9.3	332	150	7380	0.8			
	12	306	75	6952	1.1	<b>PC080+MRDV075</b>	<b>8026</b>	69
	10	341	90	7380	1.1			
	17.5	189	80	6783	1.5	<b>MRDV090</b>	<b>8014</b>	64
	14	221	100	7306	1.2			
	18	198	50	6719	2	<b>MRDV090</b>	<b>8026</b>	64
	15	224	60	7140	1.6			
	11.3	275	80	7859	1.1			
	9	315	100	8180	0.9			
	15.6	240	90	7054	2.3	<b>PC080+MRDV090</b>	<b>8014</b>	70
	11.7	297	120	7764	1.6			
	9.3	355	150	8180	1.3			
	7.8	398	180	8180	1			
10	357	90	8174	2	<b>PC080+MRDV090</b>	<b>8026</b>	70	
7.5	441	120	8180	1.4				
6	516	150	8180	1.1				
5	578	180	8180	0.9				
9.3	306	300	8180	2	<b>MRDV040+090</b>	<b>7122</b>	73	
7	403	400	8180	1.5				
5.6	470	500	8180	1.2				
17.5	201	80	8571	2.6	<b>MRDV110</b>	<b>8014</b>	65	
14	236	100	9232	2				
11.3	294	80	9931	1.9	<b>MRDV110</b>	<b>8026</b>	65	
9	338	100	10320	1.5				
7.8	425	180	10320	1.8	<b>PC080+MRDV110</b>	<b>8014</b>	70	
5.8	513	240	10320	1.3				
4.7	597	300	10320	1				
7.5	462	120	10320	2.6	<b>PC080+MRDV110</b>	<b>8026</b>	70	
6	552	150	10320	2				
5	620	180	10320	1.6				
3.8	756	240	10320	1.1				

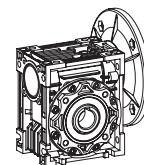

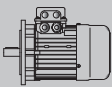

# PRESTAZIONI - PERFORMANCE PARAMETER

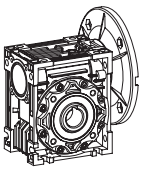

$P_1$ [kW]	$n_2$ [min <sup>-1</sup> ]	$M_2$ [Nm]	$i$	$Fr_2$ [N]	$fs$			
<b>0.55</b>	4.7	639	300	10320	2	<b>MRDV050+110</b>	<b>8014</b>	73
	3.5	826	400	10320	1.4			
	2.8	984	500	10320	1.1			
	2.3	1181	600	10320	1			
	1.9	1411	750	10320	0.9			
	3.8	756	240	13500	1.6	<b>PC080+MRDV130</b>	<b>8026</b>	70
	3	858	300	13500	1.3			
	2.8	996	500	13500	1.6	<b>MRDV063+130</b>	<b>8014</b>	74
	1.9	1471	750	13500	1.2			
	1.2	2132	1200	13500	0.8			
<b>0.75</b>	373.3	17	7.5	1433	3	<b>MRDV050</b>	<b>8012</b>	61
	280	23	10	1577	2.4			
	186.7	33	15	1805	1.7			
	140	42	20	1987	1.3			
	112	51	25	2140	1			
	93.3	58	30	2274	1.1			
	186.7	34	7.5	1805	2.1	<b>MRDV050</b>	<b>8024</b>	61
	140	44	10	1987	1.6			
	93.3	63	15	2274	1.2			
	70	81	20	2503	0.9			
	140	43	20	2597	2.3	<b>MRDV063</b>	<b>8012</b>	62
	112	52	25	2797	1.8			
	93.3	60	30	2973	2			
	70	77	40	3272	1.4			
	56	91	50	3524	1.1			
	46.7	104	60	3745	0.9			
	93.3	64	15	2973	2.2			
	70	83	20	3272	1.6			
	56	100	25	3524	1.3			
	46.7	114	30	3745	1.4			
	35	143	40	4122	1			
	120	52	7.5	2734	2.9	<b>MRDV063</b>	<b>90S6</b>	62
	90	68	10	3009	2.3			
	60	97	15	3444	1.6			
	45	123	20	3791	1.2			
	36	149	25	4084	0.9			
	30	167	30	4339	1			
	46.7	109	60	4421	1.3	<b>MRDV075</b>	<b>8012</b>	63
	28	156	100	5241	0.8			



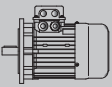

## PRESTAZIONI - PERFORMANCE PARAMETER

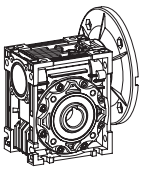
$P_1$ [kW]	$n_2$ [min <sup>-1</sup> ]	$M_2$ [Nm]	$i$	$Fr_2$ [N]	$fs$			
<b>0.75</b>	56	102	25	4160	2	<b>MRDV075</b>	<b>8024</b>	63
	46.7	117	30	4421	2			
	35	147	40	4865	1.5			
	28	177	50	5241	1.2			
	23.3	200	60	5569	1			
	60	98	15	4065	2.4	<b>MRDV075</b>	<b>90S6</b>	63
	45	126	20	4474	1.9			
	36	153	25	4820	1.4			
	30	174	30	5122	1.5			
	22.5	216	40	5637	1.1			
	18.7	280	75	6000	0.9	<b>PC080+MRDV075</b>	<b>8024</b>	69
	15.6	313	90	6375	1			
	35	141	80	5383	1.6	<b>MRDV090</b>	<b>8012</b>	64
	28	166	100	5799	1.2			
	28	184	50	5799	1.8	<b>MRDV090</b>	<b>8024</b>	64
	23.3	212	60	6163	1.5			
	17.5	258	80	6783	1.1			
	14	302	100	7306	0.9			
	30	179	30	5667	2.6			
	22.5	226	40	6238	1.8	<b>MRDV090</b>	<b>90S6</b>	64
18	271	50	6719	1.4				
15	306	60	7140	1.1				
15.6	327	90	7054	1.7				
11.7	405	120	7764	1.2	<b>PC080+MRDV090</b>	<b>8024</b>	70	
9.3	483	150	8180	0.9				
7.8	543	180	8180	0.7				
7	549	400	8180	1.1				
5.6	642	500	8180	0.9	<b>MRDV040+090</b>	<b>8012</b>	73	
17.5	274	80	8571	1.9	<b>MRDV110</b>	<b>8024</b>	65	
14	322	100	9232	1.5				
15	325	60	9023	2.1	<b>MRDV110</b>	<b>90S6</b>	65	
11.3	401	80	9931	1.4				
9	462	100	10320	1.1				
11.7	430	120	9811	2.2	<b>PC080+MRDV110</b>	<b>8024</b>	70	
9.3	506	150	10320	1.7				
7.8	580	180	10320	1.3				
5.8	700	240	10320	0.9				



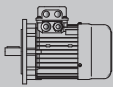

## PRESTAZIONI - PERFORMANCE PARAMETER

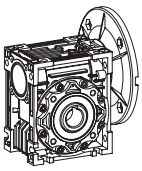
$P_1$ [kW]	$n_2$ [min <sup>-1</sup> ]	$M_2$ [Nm]	$i$	$Fr_2$ [N]	$fs$			
<b>1.1</b>	186.7	50	7.5	2359	2.6	<b>MRDV063</b>	<b>90S4</b>	62
	140	65	10	2597	2			
	93.3	93	15	2973	1.5			
	70	122	20	3272	1.1			
	56	146	25	3524	0.9			
	46.7	167	30	3745	1			
	112	78	25	3302	1.9	<b>MRDV075</b>	<b>8022</b>	63
	93.3	90	30	3509	1.9			
	70	116	40	3862	1.4			
	56	139	50	4160	1.1			
	46.7	160	60	4421	0.9			
	90	100	10	3551	2.3	<b>MRDV075</b>	<b>90L6</b>	63
	60	144	15	4065	1.6			
	45	184	20	4474	1.3			
	36	225	25	4820	1			
	30	256	30	5122	1			
	93.3	96	15	3509	2.1	<b>MRDV075</b>	<b>90S4</b>	63
	70	123	20	3862	1.7			
56	150	25	4160	1.3				
46.7	171	30	4421	1.3				
35	216	40	4865	1				
35	207	80	5383	1.1	<b>MRDV090</b>	<b>8022</b>	64	
28	244	100	5799	0.8				
36	231	25	5333	1.6	<b>MRDV090</b>	<b>90L6</b>	64	
30	263	30	5667	1.8				
22.5	331	40	6238	1.2				
18	397	50	6719	1				
15	448	60	7140	0.8				
35	225	40	5383	1.6	<b>MRDV090</b>	<b>90S4</b>	64	
28	270	50	5799	1.3				
23.3	311	60	6163	1				
22.5	345	40	7882	2.3	<b>MRDV110</b>	<b>90L6</b>	65	
18	414	50	8491	1.8				
15	476	60	9023	1.4				
11.3	588	80	9931	1				
28	281	50	7328	2.3	<b>MRDV110</b>	<b>90S4</b>	65	
23.3	324	60	7787	1.9				
17.5	402	80	8571	1.3				
14	473	100	9232	1				



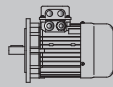

## PRESTAZIONI - PERFORMANCE PARAMETER

$P_1$ [kW]	$n_2$ [min <sup>-1</sup> ]	$M_2$ [Nm]	$i$	$Fr_2$ [N]	$f_s$			
<b>1.5</b>	373.3	35	7.5	1873	2.7	<b>MRDV063</b>	<b>90S2</b>	62
	280	46	10	2061	2.1			
	186.7	66	15	2359	1.6			
	140	86	20	2597	1.2			
	112	105	25	2797	0.9			
	93.3	120	30	2973	1			
	120	105	7.5	3227	2	<b>MRDV075</b>	<b>100L6</b>	63
	90	137	10	3551	1.7			
	60	196	15	4065	1.2			
	56	189	50	4160	0.8	<b>MRDV075</b>	<b>90S2</b>	63
	46.7	218	60	4421	0.7			
	140	90	10	3065	2.2	<b>MRDV075</b>	<b>90L4</b>	63
	93.3	130	15	3509	1.5			
	70	168	20	3862	1.3			
	56	205	25	4160	1			
46.7	233	30	4421	1				
280	46	10	2433	3.1	<b>MRDV075</b>	<b>90S2</b>	63	
186.7	67	15	2785	2.2				
140	87	20	3065	1.8	<b>MRDV075</b>	<b>90S2</b>	63	
112	106	25	3302	1.4				
93.3	123	30	3509	1.4				
70	158	40	3862	1				
90	138	10	3929	2.7				
60	201	15	4498	2.1	<b>MRDV090</b>	<b>100L6</b>	64	
45	258	20	4951	1.5				
36	314	25	5333	1.2				
30	358	30	5667	1.3				
70	172	20	4273	2.1				
56	210	25	4603	1.6	<b>MRDV090</b>	<b>90L4</b>	64	
46.7	239	30	4891	1.7				
35	307	40	5383	1.2				
28	368	50	5799	0.9				
23.3	424	60	6163	0.8				
56	194	50	4603	1.4	<b>MRDV090</b>	<b>90S2</b>	64	
46.7	227	60	4891	1.1				
45	264	20	6256	2.7	<b>MRDV110</b>	<b>100L6</b>	65	
36	322	25	6739	2.4				
30	363	30	7161	2.3				
22.5	471	40	7882	1.7				
18	565	50	8491	1.3				
15	649	60	9023	1.1				

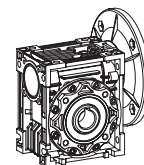
# PRESTAZIONI - PERFORMANCE PARAMETER

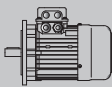



$P_1$ [kW]	$n_2$ [min <sup>-1</sup> ]	$M_2$ [Nm]	$i$	$Fr_2$ [N]	$f_s$			
<b>1.5</b>	35	319	40	6803	2.2	<b>MRDV110</b>	<b>90L4</b>	65
	28	384	50	7328	1.7			
	23.3	442	60	7787	1.4			
	17.5	548	80	8571	0.9			
	46.7	236	60	6181	2	<b>MRDV110</b>	<b>90S2</b>	65
	35	299	80	6803	1.3			
	28	353	100	7328	1			
	19.3	535	73	8298	1.9	<b>PC090+MRDV110</b>	<b>90L4</b>	70
	14.5	693	96.8	9133	1.3			
	11.6	817	121	9838	1.1			
	9.6	936	145.2	10320	0.8			
	9.3	891	300	10320	1.4	<b>MRDV050+110</b>	<b>90S2</b>	73
	7	1153	400	10320	1			
	5.6	1373	500	10320	0.8			
	22.5	478	40	10309	2.3	<b>MRDV130</b>	<b>100L6</b>	66
	18	573	50	11105	1.8			
	15	659	60	11801	1.4	<b>MRDV130</b>	<b>100L6</b>	66
	11.3	815	80	12989	1.1			
	17.5	557	80	11210	1.5	<b>MRDV130</b>	<b>90L4</b>	66
	14	655	100	12076	1.1			
19.3	542	73	10853	2.6	<b>PC090+MRDV130</b>	<b>90L4</b>	70	
14.5	693	96.8	11945	1.9				
11.6	830	121	12868	1.5				
9.6	936	145.2	13500	1.1				
7.2	1149	194	13500	0.8				
9.3	915	300	13500	1.9	<b>MRDV063+130</b>	<b>90S2</b>	74	
7	1166	400	13500	1.4				
5.6	1389	500	13500	1.1				
4.7	1789	300	13500	1	<b>MRDV063+130</b>	<b>90L4</b>	74	
3.5	2279	400	13500	0.7				
<b>2.2</b>	373.3	51	7.5	1873	1.8	<b>MRDV063</b>	<b>90L2</b>	62
	280	67	10	2061	1.5			
	186.7	97	15	2359	1.1			
	186.7	100	7.5	2785	1.8	<b>MRDV075</b>	<b>100LA4</b>	63
	140	132	10	3065	1.5			
	93.3	191	15	3509	1			

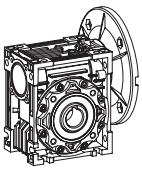



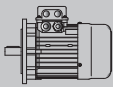

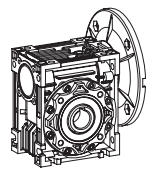

## PRESTAZIONI - PERFORMANCE PARAMETER

$P_1$ [kW]	$n_2$ [min <sup>-1</sup> ]	$M_2$ [Nm]	$i$	$Fr_2$ [N]	$fs$			
<b>2.2</b>	373.3	51	7.5	2210	2.5	<b>MRDV075</b>	<b>90L2</b>	63
	280	68	10	2433	2.1			
	186.7	98	15	2785	1.5			
	140	128	20	3065	1.3			
	112	156	25	3302	1			
	93.3	180	30	3509	0.9			
	186.7	101	7.5	3081	2.9	<b>MRDV090</b>	<b>100LA4</b>	64
	140	134	10	3391	2.3			
	93.3	194	15	3882	1.9			
	70	252	20	4273	1.4			
	56	308	25	4603	1.1			
	46.7	351	30	4891	1.2			
	120	156	7.5	3570	2.2	<b>MRDV090</b>	<b>112M6</b>	64
	90	203	10	3929	1.8			
	60	294	15	4498	1.4			
	45	378	20	4951	1			
	140	131	20	3391	2	<b>MRDV090</b>	<b>90L2</b>	64
	112	159	25	3653	1.6			
	93.3	185	30	3882	1.7			
	70	237	40	4273	1.2			
	56	285	50	4603	0.9			
	70	255	20	5399	2.5	<b>MRDV110</b>	<b>100LA4</b>	65
	56	315	25	5816	2.2			
	46.7	356	30	6181	2			
	35	468	40	6803	1.5			
	28	563	50	7328	1.2			
	23.3	648	60	7787	1			
	90	205	10	4965	3.5	<b>MRDV110</b>	<b>112M6</b>	65
	60	298	15	5684	2.6			
	45	388	20	6256	1.9			
	36	473	25	6739	1.6			
	30	532	30	7161	1.6			
	112	163	25	4616	3.1	<b>MRDV110</b>	<b>90L2</b>	65
	93.3	187	30	4905	3			
	70	246	40	5399	2.1			
	56	296	50	5816	1.7			
	46.7	347	60	6181	1.4			
	38.6	398	73	6586	2.1	<b>PC090+MRDV110</b>	<b>90L2</b>	70
	28.9	516	96.8	7249	1.5			
	23.1	617	121	7809	1.2			

# PRESTAZIONI - PERFORMANCE PARAMETER

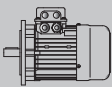

$P_1$ [kW]	$n_2$ [min <sup>-1</sup> ]	$M_2$ [Nm]	$i$	$Fr_2$ [N]	$fs$						
<b>2.2</b>	35	468	40	8897	2.2	<b>MRDV130</b>	<b>100LA4</b>	66			
	28	563	50	9584	1.7						
	23.3	648	60	10185	1.4						
	17.5	816	80	11210	1						
	36	479	25	8814	2.2	<b>MRDV130</b>	<b>112M6</b>	66			
	30	546	30	9366	2.1						
	22.5	700	40	10309	1.6						
	18	840	50	11105	1.2	<b>MRDV130</b>	<b>112M6</b>	66			
	15	966	60	11801	1						
	35	438	80	8897	1.3	<b>MRDV130</b>	<b>90L2</b>	66			
	28	525	100	9584	1						
	38.6	409	73	8614	2.9	<b>PC090+MRDV130</b>	<b>90L2</b>	70			
28.9	545	96.8	9481	2							
23.1	654	121	10213	1.6							
19.3	752	145.2	10853	1.3							
<b>3</b>	373.3	70	7.5	2210	1.9	<b>MRDV075</b>	<b>100L2</b>	63			
	280	92	10	2433	1.6						
	186.7	137	7.5	2785	1.4	<b>MRDV075</b>	<b>100LB4</b>	63			
	140	180	10	3065	1.1						
	93.3	261	15	3509	0.8						
	373.3	71	7.5	2446	3	<b>MRDV090</b>	<b>100L2</b>	64			
	280	92	10	2692	2.6						
	186.7	138	7.5	3081	2.1	<b>MRDV090</b>	<b>100LB4</b>	64			
	140	182	10	3391	1.7						
	93.3	264	15	3882	1.4						
	70	344	20	4273	1						
	56	420	25	4603	0.8						
	46.7	479	30	4891	0.9						
	93.3	264	15	4905	2.5				<b>MRDV110</b>	<b>100LB4</b>	64
	70	348	20	5399	1.9						
	56	430	25	5816	1.6						
	46.7	485	30	6181	1.5						
	35	638	40	6803	1.1						
	28	767	50	7328	0.9						
	120	212	7.5	4511	3.1	<b>MRDV110</b>	<b>132S6</b>	64			
	90	280	10	4965	2.5						
	60	406	15	5684	1.9						
	45	528	20	6256	1.4						

# DIMENSIONI MRDV - NMRV SERIES DIMENSIONS

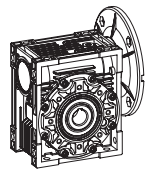

## MRDV 075

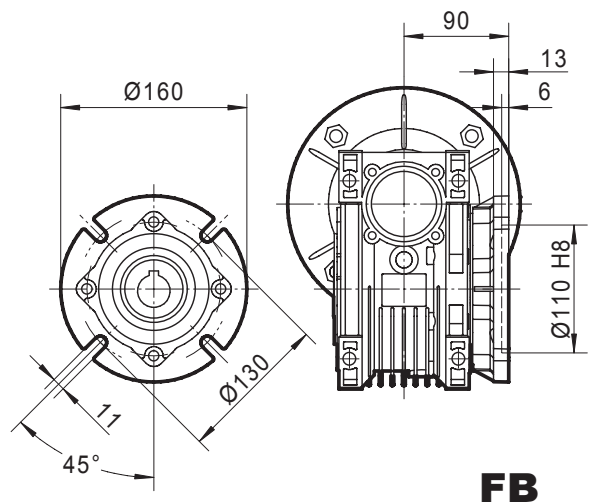
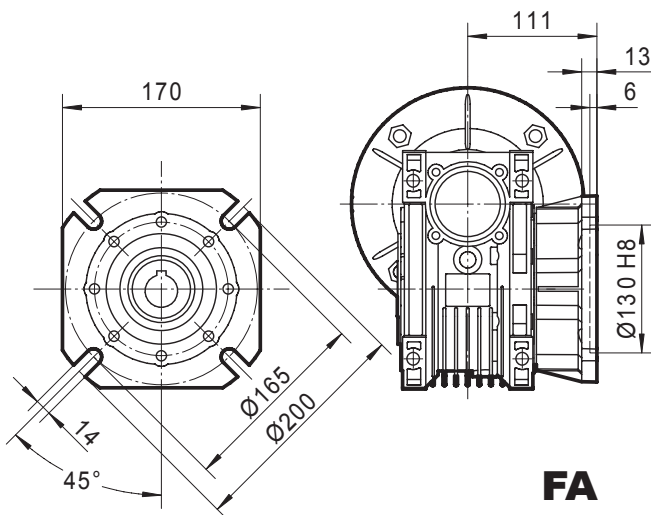
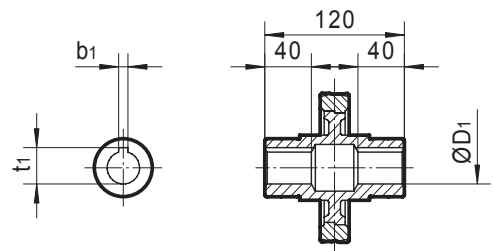
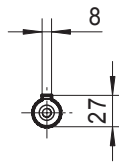
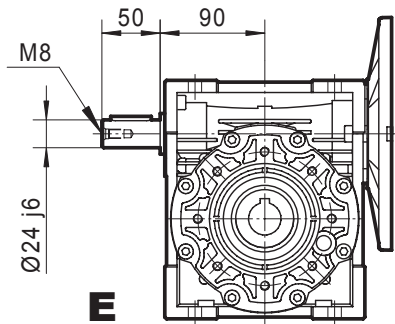
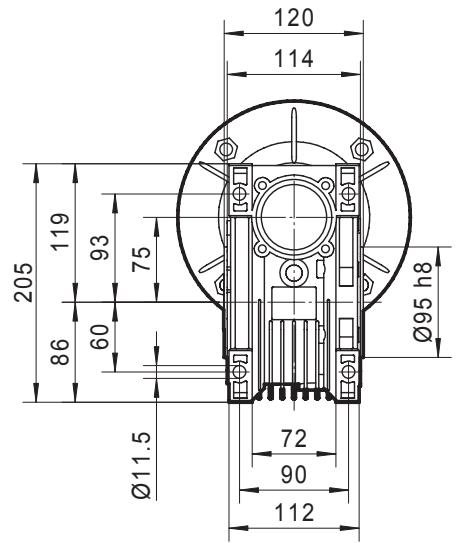
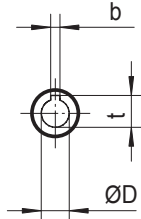
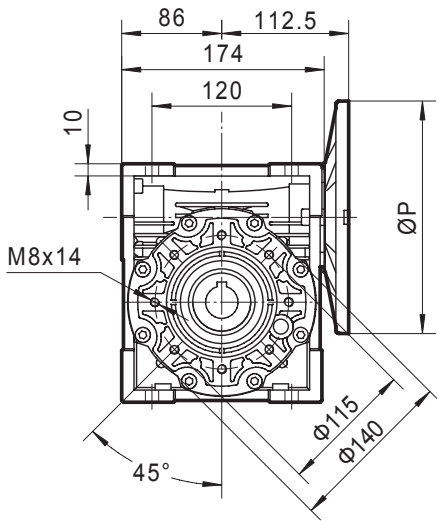

**Peso senza motore ≈ 9 kg** Weight without motor ≈ 9 kg  
**er i dati dei motori (P, D, b, t), riferirsi alla tab. a pag. 78**

For the dimensions concerning the motor connection area (P, D, b, t) please refer to the table shown at page 78.

Albero uscita - Output size		
ØD <sub>1</sub> H8	b <sub>1</sub>	t <sub>1</sub>
Ø28	8	31.3
Ø35 *	10*	38.3 *

(\*) Modello non standard

(\*) Nonstandard model

# Esplso e parti di ricambio - EXPLODED VIEW & NAME OF PARTS

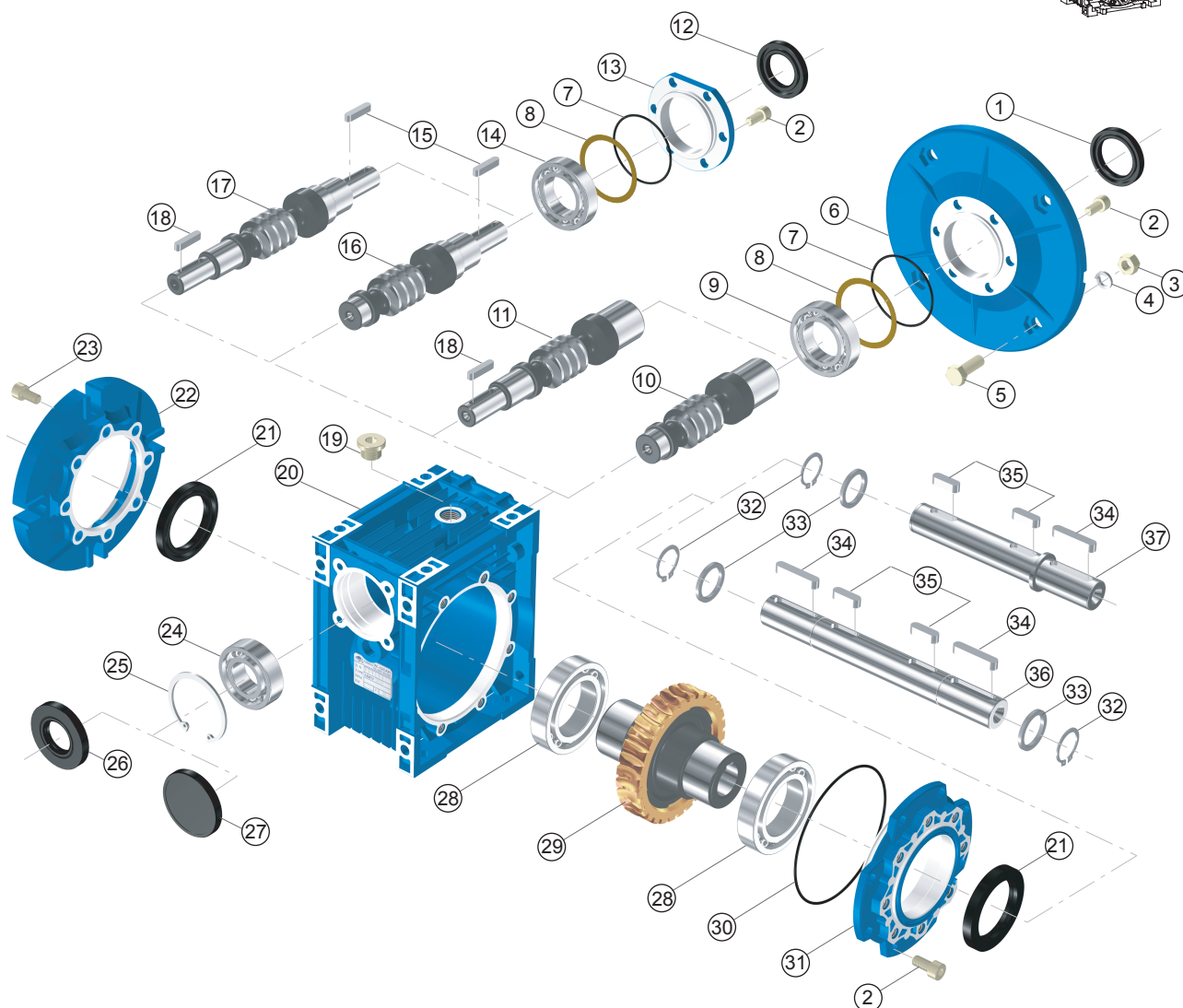
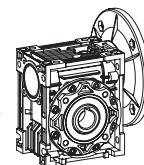

- 1. Anello di tenuta** - oil seal
- 2. Vite** - inner hex screw
- 3. Dado** - nut
- 4. Rondella** - spring washer
- 5. Bullone** - hex screw
- 6. Flangia in ingresso** - input flange
- 7. O-Ring** - O-Ring
- 8. Distanziale** - adjust spacer
- 9. Cuscinetto** - bearing
- 10. Vite forata in ingresso** - hole input worm
- 11. Vite cilindrica in ingresso e albero maschio** - hole input and shaft & output worm
- 12. Anello di tenuta** - oil seal
- 13. Coperchio in ingresso** - input cover
- 14. Cuscinetto** - Bearing
- 15. Chiavetta** - key
- 16. Albero in ingresso** - shaft input worm
- 17. Albero in ingresso e vite in uscita** - shaft input and shaft output worm
- 18. Chiavetta** - key

- 19. Tappo per olio** - oil plug
- 20. Carcassa** - casing
- 21. Anello di tenuta** - oil seal
- 22. Flangia in uscita** - output flange
- 23. Bullone** - inner hex screw
- 24. Cuscinetto** - bearing
- 25. Seeger** - hole-circlip
- 26. Anello di tenuta** - oil seal
- 27. Coperchio** - cover
- 28. Cuscinetto** - bearing
- 29. Vite** - worm wheel
- 30. O-Ring** - O-Ring
- 31. Coperchio in uscita** - output cover
- 32. Seeger albero** - shaft-circlip
- 33. Distanziale** - spacer
- 34. Chiavetta** - key
- 35. Chiavetta** - key
- 36. Albero bisporgente in uscita** - double output shaft
- 37. Albero sporgente in uscita** - single output shaft