

- SERIE MRDV -

Riduttori a Vite Senza Fine -

MRDV Series Worm-Gear Speed Reducers



ELLE.GI SRL

Organi di Trasmissione

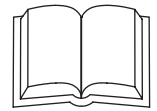

PARAMETRI Mesh parameter

	i	7.5	10	15	20	25	30	40	50	60	80	100
MRDV025	Z ₁	4	3	2	2	2	1	1	1	1		
	M _n	1.3	1.3	1.3	0.995	0.8	1.3	0.995	0.8	0.67		
	γ	25°18'	19°31'	13°18'	11°02'	9°05'	6°44'	5°34'	4°34'	3°55'		
	η _d (1400)	0.85	0.83	0.79	0.75	0.71	0.67	0.62	0.58	0.55		
	η _s	0.71	0.68	0.61	0.56	0.5	0.46	0.41	0.36	0.34		
MRDV030	Z ₁	4	3	2	2	1	1	1	1	1	1	
	M _n	1.44	1.44	1.44	1.1	1.7	1.44	1.1	0.89	0.74	0.56	
	γ	18°55'	14°25'	9°44'	7°50'	5°33'	4°54'	3°55'	3°17'	2°43'	2°07'	
	η _d (1400)	0.85	0.82	0.77	0.73	0.68	0.65	0.59	0.55	0.51	0.44	
	η _s	0.67	0.63	0.55	0.5	0.43	0.39	0.35	0.31	0.27	0.23	
MRDV040	Z ₁	4	3	2	2	2	1	1	1	1	1	1
	M _n	2.05	2.05	2.05	1.56	1.27	2.05	1.56	1.27	1.06	0.8	0.65
	γ	23°54'	18°23'	12°30'	10°03'	8°45'	6°19'	5°04'	4°24'	3°42'	2°52'	2°29'
	η _d (1400)	0.87	0.85	0.82	0.78	0.75	0.7	0.65	0.62	0.58	0.52	0.47
	η _s	0.71	0.67	0.6	0.55	0.51	0.45	0.4	0.36	0.32	0.28	0.24
MRDV050	Z ₁	4	3	2	2	2	1	1	1	1	1	1
	M _n	2.56	2.56	2.56	1.95	1.58	2.56	1.95	1.58	1.32	1	0.8
	γ	23°49'	18°19'	12°27'	10°03'	8°33'	6°18'	5°04'	4°18'	3°38'	2°52'	2°17'
	η _d (1400)	0.88	0.86	0.82	0.79	0.76	0.72	0.67	0.63	0.59	0.53	0.49
	η _s	0.7	0.66	0.59	0.55	0.51	0.44	0.39	0.35	0.32	0.27	0.23
MRDV063	Z ₁	4	3	2	2	2	1	1	1	1	1	1
	M _n	3.25	3.25	3.25	2.48	2	3.25	2.48	2	1.68	1.27	1.02
	γ	24°31'	18°53'	12°51'	10°29'	8°45'	6°30'	5°17'	4°24'	3°49'	2°59'	2°26'
	η _d (1400)	0.88	0.87	0.83	0.81	0.78	0.74	0.7	0.66	0.62	0.57	0.51
	η _s	0.71	0.67	0.6	0.55	0.51	0.45	0.4	0.36	0.33	0.28	0.24
MRDV075	Z ₁	4	3	2	2	2	1	1	1	1	1	1
	M _n	3.95	3.95	3.95	3	2.42	3.95	3	2.42	2.03	1.54	1.24
	γ	26°38'	20°37'	14°05'	11°19'	9°29'	7°09'	5°43'	4°46'	4°01'	3°17'	2°44'
	η _d (1400)	0.89	0.88	0.85	0.82	0.8	0.76	0.72	0.69	0.65	0.6	0.55
	η _s	0.71	0.68	0.61	0.57	0.53	0.46	0.42	0.38	0.35	0.29	0.26
MRDV090	Z ₁	4	3	2	2	2	1	1	1	1	1	1
	M _n	4.84	4.84	4.84	3.69	2.98	4.84	3.69	2.98	2.5	1.89	1.52
	γ	29°05'	22°39'	15°33'	12°50'	10°53'	7°55'	6°30'	5°29'	4°46'	3°45'	3°06'
	η _d (1400)	0.9	0.89	0.86	0.84	0.82	0.78	0.75	0.72	0.69	0.63	0.59
	η _s	0.73	0.7	0.64	0.6	0.56	0.49	0.45	0.41	0.38	0.32	0.28
MRDV110	Z ₁	4	3	2	2	2	1	1	1	1	1	1
	M _n	5,875	5,875	5,875	4.62	3.73	5,875	4.62	3.73	3.13	2.37	1.91
	γ	28°15'	21°57'	15°02'	14°42'	12°33'	7°39'	7°29'	6°21'	5°33'	4°27'	3°46'
	η _d (1400)	0.9	0.89	0.86	0.85	0.84	0.79	0.78	0.75	0.72	0.67	0.63
	η _s	0.72	0.69	0.63	0.62	0.59	0.48	0.48	0.44	0.41	0.36	0.32
MRDV130	Z ₁	4	3	2	2	2	1	1	1	1	1	1
	M _n	6.97	6.97	6.97	5.4	4.37	6.97	5.4	4.37	3.67	2.77	2.23
	γ	28°43'	22°20'	15°19'	13°47'	11°54'	7°48'	7°00'	6°01'	5°16'	4°07'	3°27'
	η _d (1400)	0.91	0.89	0.87	0.86	0.84	0.8	0.78	0.75	0.72	0.68	0.64
	η _s	0.72	0.69	0.63	0.61	0.58	0.49	0.46	0.43	0.39	0.34	0.3

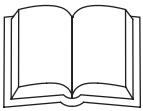

DATI TECNICI - TECHNICAL DATA

PREDISPOSIZIONI - Predisposition

(*) Per un ingresso con motore speciale contattare il nostro ufficio tecnico

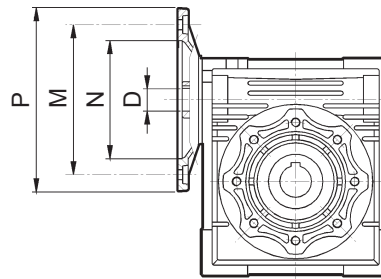

(*) If you want special key, please call our Technical Service

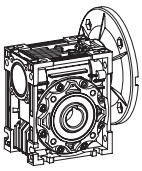

MRDV	PAM IEC	N	M	P	D											
					7.5	10	15	20	25	30	40	50	60	80	100	
025	56B14	50	65	80	9	9	9	9		9	9	9	9			
030	63B5	95	115	140	11	11	11	11	11	11	11	11				
	63B14	60	75	90												
	56B5	80	100	120	9	9	9	9	9	9	9	9	9	9		
	56B14	50	65	80												
040	71B5	110	130	160	14	14	14	14	14	14	14					
	71B14	70	85	105												
	63B5	95	115	140	11	11	11	11	11	11	11	11	11	11	11	11
	63B14	60	75	90												
	56B5	80	100	120								9	9	9	9	
050	80B5	130	165	200	19	19	19	19	19	19						
	80B14	80	100	120												
	71B5	110	130	160	14	14	14	14	14	14	14	14	14	14		
	71B14	70	85	105												
	63B5	95	115	140							11	11	11	11	11	
063	90B5	130	165	200	24	24	24	24	24	24						
	90B14	95	115	140												
	80B5	130	165	200	19	19	19	19	19	19	19	19	19			
	80B14	80	100	120												
	71B5	110	130	160												
	71B14	70	85	105							14	14	14	14	14	
075	100/112B5	180	215	250	28	28	28									
	100/112B14	110	130	160												
	90B5	130	165	200	24	24	24	24	24	24						
	90B14	95	115	140												
	80B5	130	165	200				19	19	19	19	19	19	19	19	19
	80B14	80	100	120												
	71B5	110	130	160								14	14	14	14	14
090	100/112B5	180	215	250	28	28	28	28	28	28						
	100/112B14	110	130	160												
	90B5	130	165	200	24	24	24	24	24	24	24	24	24			
	90B14	95	115	140												
	80B5	130	165	200							19	19	19	19	19	19
	80B14	80	100	120												
110	132B5	230	265	300	38*	38*	38*	38*								
	100/112B5	180	215	250	28	28	28	28	28	28	28	28	28			
	90B5	130	165	200					24	24	24	24	24	24	24	24
	80B5	130	165	200											19	19
130	132B5	230	265	300	38*	38*	38*	38*	38*	38*	38*					
	100/112B5	180	215	250					28	28	28	28	28	28	28	28
	90B5	130	165	200											24	24



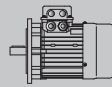

PRESTAZIONI - PERFORMANCE PARAMETER

P_1 [kW]	n_2 [min ⁻¹]	M_2 [Nm]	i	Fr_2 [N]	fs			
0.06	186.7	2.6	7.5	503	4.2	MRDV025	5614	58
	140	3.4	10	553	3.5			
	93.3	4.9	15	633	2.5			
	70	6.1	20	697	2			
	46.7	8.2	30	798	1.6			
	35	10	40	878	1.3			
	28	12	50	946	0.9			
23.3	14	60	1006	0.7				
	186.7	2.6	7.5	683	6.9	MRDV030	5614	59
	140	3.4	10	752	5.4			
	93.3	4.7	15	861	3.8			
	70	6	20	948	3			
	56	7	25	1021	3			
	46.7	8	30	1085	2.5			
	35	9.7	40	1194	1.9			
	28	11	50	1286	1.5			
	23.3	13	60	1367	1.3			
	17.5	14	80	1504	0.9			
	14	25	100	1620	1.3	MRDV025+030	5614	71
	9.3	32	150	1830	0.9			
	7	41	200	1830	0.7			
	5.6	44	250	1830	0.8			
	4.7	59	300	3490	1.2	MRDV025+040	5614	71
	3.5	71	400	3490	0.9			
	2.8	82	500	3490	0.7			
	2.3	101	600	3490	0.6			
	1.9	116	750	3490	0.5			
	1.6	143	900	3490	0.5			
	1.2	171	1200	3490	0.4			
	0.9	197	1500	3490	0.3			
	0.8	217	1800	3490	0.3			
	0.6	268	2400	3490	0.2			
	0.5	324	3000	3490	0.2			
	0.4	294	4000	3490	0.1			
	0.3	356	5000	3490	0.1			
	4.7	57	300	3490	1.3	MRDV030+040	5614	72
	3.5	70	400	3490	0.9			
	2.8	96	500	3490	0.6			
	2.3	104	600	3490	0.7			
	1.9	121	750	3490	0.6	MRDV030+040	5614	72
	1.6	139	900	3490	0.5			
	1.2	166	1200	3490	0.4			
	0.9	196	1500	3490	0.4			
	0.8	218	1800	3490	0.3			

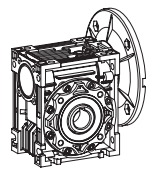

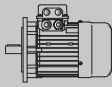
PRESTAZIONI - PERFORMANCE PARAMETER

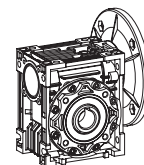

P_1 [kW]	n_2 [min ⁻¹]	M_2 [Nm]	i	Fr_2 [N]	fs				
0.06	0.58	261	2400	3490	0.2	MRDV030+040	5614	72	
	0.4	300	3200	3490	0.2				
	0.4	279	4000	3490	0.1				
	0.28	338	5000	3490	0.1				
	1.6	141	900	4840	1	MRDV030+050	5614	72	
	1.2	169	1200	4840	0.7				
	0.93	199	1500	4840	0.7				
	0.78	222	1800	4840	0.7				
	0.6	266	2400	4840	0.5				
	0.5	307	3000	4840	0.4				
	0.35	288	4000	4840	0.3				
	0.29	311	4800	4840	0.3				
	0.9	204	1500	6270	1.1	MRDV030+063	5614	72	
	0.78	225	1800	6270	0.9				
	0.58	276	2400	6270	0.8				
	0.47	319	3000	6270	0.7				
	0.35	306	4000	6270	0.6				
	0.28	360	5000	6270	0.4				
	0.6	330	2400	7380	1.1	MRDV040+075	5614	73	
	0.47	377	3000	7380	0.8				
	0.35	355	4000	7380	0.7				
	0.28	419	5000	7380	0.5				
	0.5	406	3000	8180	1.4	MRDV040+090	5614	73	
	0.35	365	4000	8180	1.3				
	0.28	431	5000	8180	1				
	0.09	373.3	2	7.5	399	3.9	MRDV025	5612	58
		280	2.6	10	439	3.4			
		186.7	3.8	15	503	2.4			
140		4.9	20	553	1.9				
93.3		6.7	30	633	1.3				
70		8.3	40	697	1.1				
56		10	50	751	0.9				
186.7		3.9	7.5	503	2.8	MRDV025			
140		5.1	10	553	2.4				
93.3		7.3	15	633	1.6				
70		9.2	20	697	1.3				
46.7		12	30	798	1.1				
35		15	40	878	0.9				
373.3		2	7.5	542	6.5		MRDV030	5612	59
280		2.6	10	597	5				
186.7		3.7	15	683	3.5				
140		4.8	20	752	2.5				

PRESTAZIONI - PERFORMANCE PARAMETER

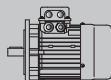

P_1 [kW]	n_2 [min ⁻¹]	M_2 [Nm]	i	Fr_2 [N]	fs				
0.09	3.5	107	400	4840	1.2	MRDV030+050	5624	72	
	2.8	123	500	4840	1				
	2.3	159	600	4840	0.9				
	1.9	185	750	4840	0.8				
	1.6	212	900	4840	0.7				
	1.6	200	900	6270	1	MRDV030+063	5624	72	
	1.2	263	1200	6270	0.9				
	0.93	305	1500	6270	0.7				
	0.9	360	1500	7380	1.1	MRDV040+075	5624	73	
	0.78	404	1800	7380	1				
	0.58	496	2400	7380	0.7				
	0.5	609	3000	8180	0.9	MRDV040+090	5624	73	
	0.35	548	4000	8180	0.8				
	0.12	373.3	2.7	7.5	399	3	MRDV025	5622	58
		280	3.5	10	439	2.6			
186.7		5	15	503	1.8				
140		6.5	20	553	1.4				
93.3		9	30	633	1				
70		11	40	697	0.8				
186.7		5.2	7.5	683	3.4	MRDV030	6314	59	
140		6.7	10	752	2.7				
93.3		9.5	15	861	1.9				
70		12	20	948	1.5				
56		14	25	1021	1.5				
46.7		16	30	1085	1.3				
35		19	40	1194	0.9				
28		23	50	1286	0.8				
46.7		17	30	2087	2.6	MRDV040	6314	60	
35		21	40	2298	1.9				
28		25	50	2475	1.5				
23.3		28	60	2630	1.3				
17.5		34	80	2895	1				
14		38	100	3118	0.8				
18.7		42	75	2833	1.2	PC063+MRDV040	6314	67	
15.6		46	90	3011	1.2				
11.7		57	120	3314	0.9				
9.3		66	150	3490	0.7				
7.8		74	180	3490	0.6				
23.3		29	60	3610	2.3	MRDV050	6314	61	
17.5		35	80	3973	1.9				
14		40	100	4280	1.4				

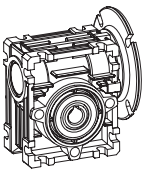

DIMENSIONI MRDV – MRDV SERIES DIMENSIONS

Riduttori Vite Senza Fine - (MRDV/RDV) Worm-gear speed reducer (MRDV/RDV)

MRDV **025**

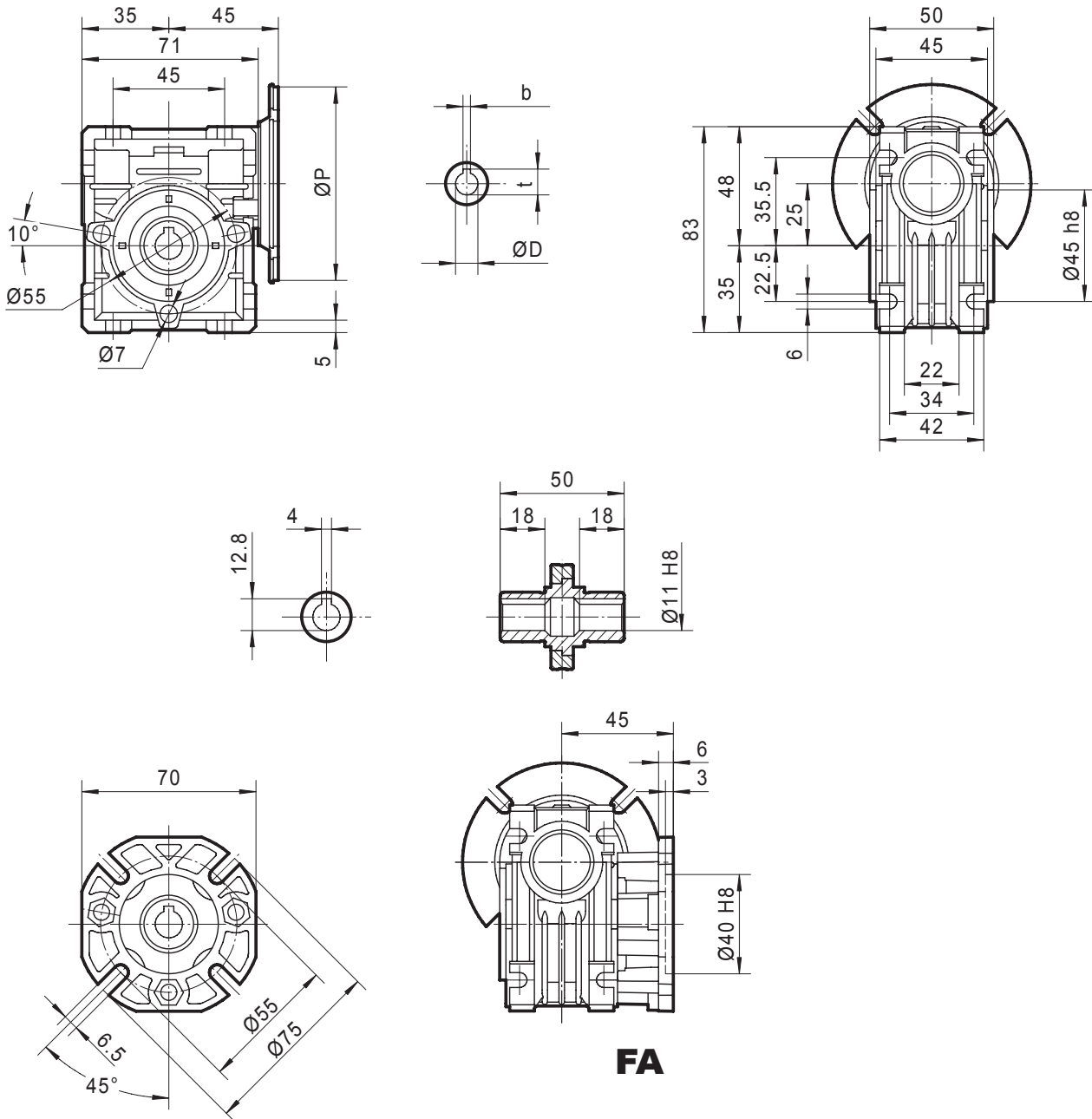

Peso senza motore ≈ 0.7 kg

Weight without motor ≈ 0.7 kg

Per le dimensioni dei motori, dati (P, D, b, t), consultare la tabella a pag. 78

For the dimensions concerning the motor connection area (P, D, b, t) please refer to the table shown at page 78.

Esplso e parti di ricambio - EXPLODED VIEW & NAME OF PARTS

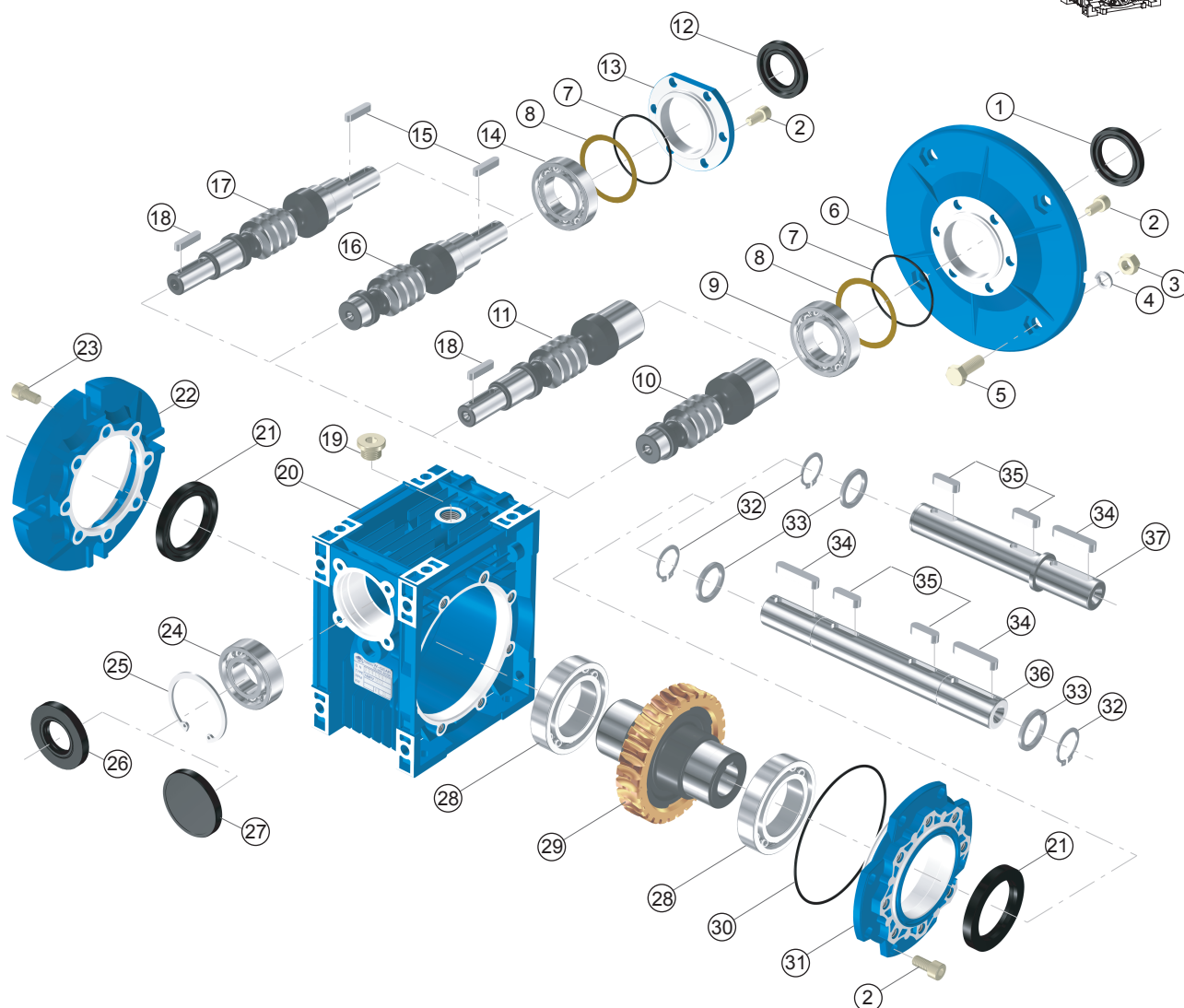
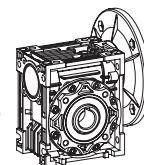

- 1. Anello di tenuta** - oil seal
- 2. Vite** - inner hex screw
- 3. Dado** - nut
- 4. Rondella** - spring washer
- 5. Bullone** - hex screw
- 6. Flangia in ingresso** - input flange
- 7. O-Ring** - O-Ring
- 8. Distanziale** - adjust spacer
- 9. Cuscinetto** - bearing
- 10. Vite forata in ingresso** - hole input worm
- 11. Vite cilindrica in ingresso e albero maschio** - hole input and shaft & output worm
- 12. Anello di tenuta** - oil seal
- 13. Coperchio in ingresso** - input cover
- 14. Cuscinetto** - Bearing
- 15. Chiavetta** - key
- 16. Albero in ingresso** - shaft input worm
- 17. Albero in ingresso e vite in uscita** - shaft input and shaft output worm
- 18. Chiavetta** - key

- 19. Tappo per olio** - oil plug
- 20. Carcassa** - casing
- 21. Anello di tenuta** - oil seal
- 22. Flangia in uscita** - output flange
- 23. Bullone** - inner hex screw
- 24. Cuscinetto** - bearing
- 25. Seeger** - hole-circlip
- 26. Anello di tenuta** - oil seal
- 27. Coperchio** - cover
- 28. Cuscinetto** - bearing
- 29. Vite** - worm wheel
- 30. O-Ring** - O-Ring
- 31. Coperchio in uscita** - output cover
- 32. Seeger albero** - shaft-circlip
- 33. Distanziale** - spacer
- 34. Chiavetta** - key
- 35. Chiavetta** - key
- 36. Albero bisporgente in uscita** - double output shaft
- 37. Albero sporgente in uscita** - single output shaft